

SURFBOARDS[®]

THE BREADBOARDING MEDIUM FOR **SURFACE MOUNT**™



33000 SERIES APPLICATION SPECIFIC ADAPTERS

IDS33308
REV A- 10-2011

MODEL **33308**
8 LEAD **.35 mm** PITCH DEVICES
DEVICE LEAD WIDTH 1.0 To Max 2.5 MM

ACCEPTS

PARTIAL LISTING

ON SEMI

ULLGA8 1.4x1.0,0.35P

TEXAS INST.

DQE (R-PX2SON-N8)

ALWAYS CONSULT DEVICE DATA SHEET TO INSURE PROPER FIT

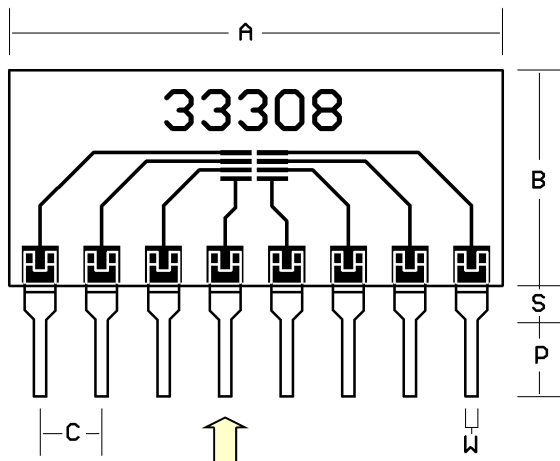

**SINGLE-IN-LINE (SIP) PINS
ON .100 in. CENTERS**

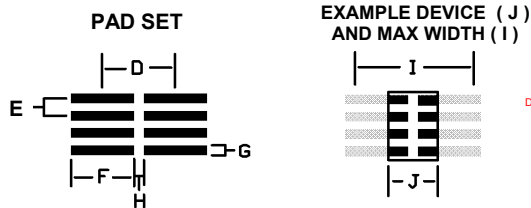

DRAWINGS
NOT TO
SCALE

MOUNTING PADS ARE OVERSIZED IN LENGTH TO ACCEPT A WIDER RANGE OF DEVICE WIDTHS AND TOLERANCES AND TO PERMIT HAND SOLDERING.
[SEE WEBSITE FOR SOLDERING SUGGESTIONS](#)

BOARD SPECIFICATIONS

BOARD MATERIAL: .8mm, +/- .13mm .031in +/- .005 in. Thick G-10 FR-4 Glass Epoxy or equivalent.

CIRCUITS: 1 oz. Copper with RoHS compliant Lead Free solder coating. Patten Position on board +/- .5mm .020in.



RoHS
Compliant
EC 2002/95

**JUST ADD PARTS
AND
PLUG-IN™**

FIG.	MM	IN.	NOTE:
A	20.32	.800	BOARD WIDTH +/- .5mm .020in.
B	8.89	.350	BOARD HEIGHT +/- .5mm .020in.
C	2.54	.100	SIP PIN SPACE +/- .20mm .008in.
D	1.5	.059	PAD CENTERLINE
E	.35	.014	DEVICE LEAD PITCH
F	1.3	.051	PAD LENGTH
G	.2	.008	PAD WIDTH
H	.2	.008	GAP
I	2.5	.098	MAX LEAD WIDTH
J	1.0	.039	TYPICAL LEAD WIDTH
P	3.3	.130	LENGTH FROM SHOULDER +/- .5mm .020in.
S	1.57	.062	PIN SHOULDER HEGHT
W	.5	.020	PIN WIDTH

TOLERANCES: If not noted are +/- 20%. Nominal values are given. Controlling unit is Millimeters. Values rounded to nearest decimal. Slight Variations due to manufacturing process can occur.

Copyright 2011 by Capital Advanced Technologies, Inc. All rights reserved. Surfboards is a registered trademark of Capital Advanced Technologies, Inc. The Breadboarding medium for surface mount, Just add parts and plug-in, and the Leaf Circuit Logo are trademarks of Capital Advanced Technologies, Inc. All other trademarks are the property of their respective owners. Specifications, availability, and price is subject to change without notice. All information given is believed to be accurate but is not guaranteed. The user of information given or products represented by such information is responsible for determining the suitability of said information or products for a given purpose. No inducement is intended or permission granted for infringement of any patent or unauthorized use of any intellectual property of Capital Advanced Technologies or others.

CAPITAL ADVANCED TECHNOLOGIES, INC.
CAROL STREAM, INLINOIS. USA PHONE 630-690-1696 FAX 630-690-2498
WWW.CapitalAdanced.Com

MADE
IN
USA