

PART NUMBER	REV	FIRST USED	POWER UNIT	FEED TYPE	DESCRIPTION
1855205-1	B	122500-1	LEADMAKER	POST FEED	CUTS CARRIER
1855205-2	B	565435-5	BENCH MODEL K	PRE FEED	CUTS CARRIER
1855205-3	B	354500-1	BENCH MODEL G	PRE FEED	CUTS CARRIER
1855205-6	B	122500-1	LEADMAKER	POST FEED	CONTINUOUS CARRIER
7-1855205-7	A	-	-	-	SPARE PARTS

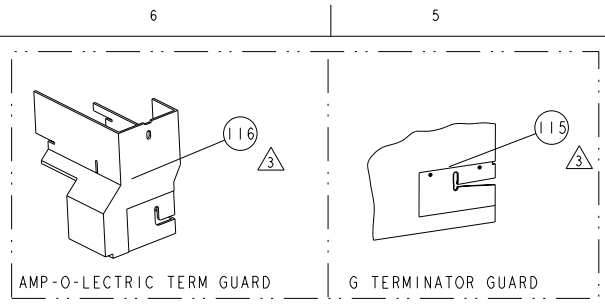

TERMINAL NAME: METRI-PACK 280			
TE PN	PACKARD PN	PACKARD TERMINAL - PACKARD CRIMP SPECS	
283558-1	12034046		
286558-2	12015823		
-	-	4 CRIMP HEIGHT	WIRE SIZE
-	-	1.55±0.05mm [.061±.002]	1mm ²
-	-	1.35±0.05mm [.053±.002]	0.8mm ² or 18AWG
-	-	1.25±0.05mm [.049±.002]	0.5mm ² or 20AWG
-	-	-	-
-	-	REF SETTING	-
-	-	A9	-
-	-	D1	-
-	-	D7	-
-	-	-	-
CRIMP	SIZE	TYPE	RANGE
-	2.39mm [.094]	F	0.5-1mm
-	3.43mm [.135]	F	∅2.03-3.12
WIRE STRIP LENGTH	TERM APPL SPEC	FEED	APPLICATOR INSTRUCTIONS
5.2 -6mm	NONE	15.3mm	408-8040
			SET UP GAGE 458637-1

LOC	DIST	REVISIONS			
A	66	REV	DESCRIPTION	DATE	BY
A	66	1	RELEASED	18APR2007	RK
A	66	2	ECR-10-004670	03MAR2010	MY

- △ RECOMMENDED SPARE PARTS
- △ GREASE LIGHTLY
- △ GUARD MUST BE IN PLACE WHEN OPERATING APPLICATOR IN A BENCH MACHINE
- △ PRIMARY CRIMP IS LISTED. SECONDARY CRIMP HEIGHT IS .009±.003 HIGHER THAN PRIMARY CRIMP HEIGHT.

• WARNING
ON INSTALLATION, SET WIRE DISC TO LARGEST WIRE SIZE SETTING. USE OF SETTINGS BELOW MIN. REQUIRED CRIMP HEIGHT SETTING WILL CAUSE DAMAGE TO CRIMP TOOLING.

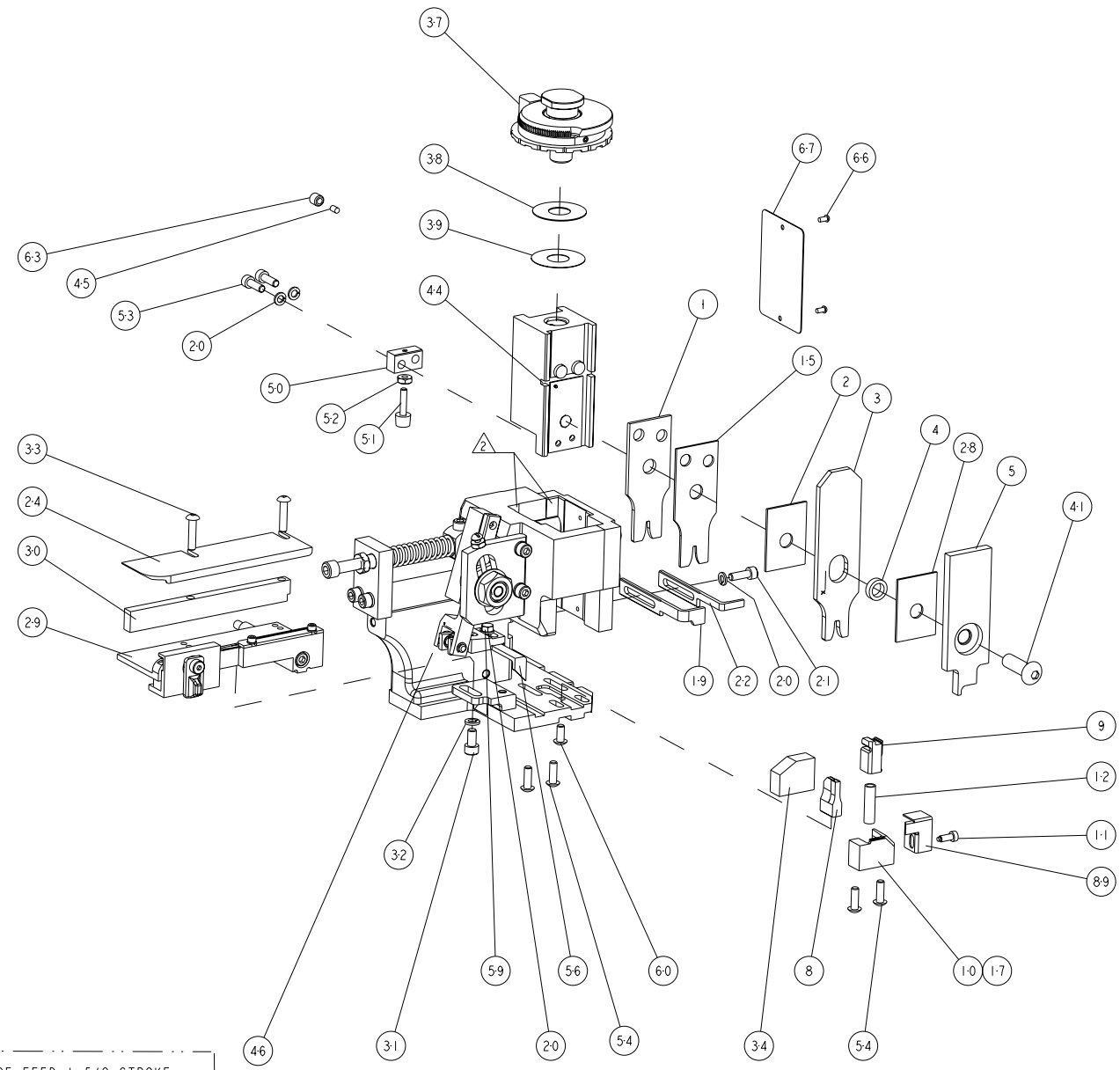
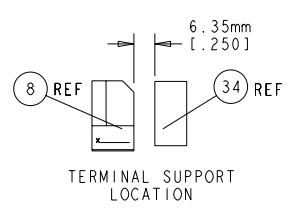
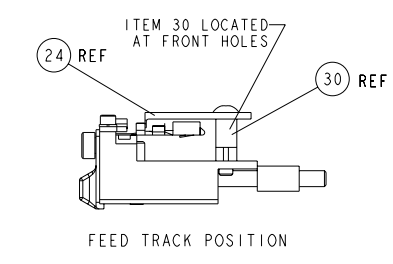
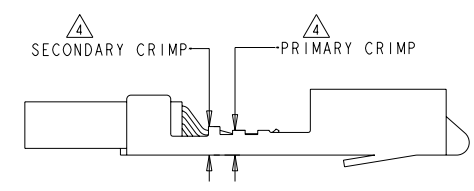

△	-	-	-	REF	-	..	455749-1	GUARD WINDOW	116
△	-	-	-	REF	-	..	679532-1	INSERT, GUARD	115
-	-	-	-	-	-	-	1-21002-7	SCR, BTN SKT HD CAP 6-32 X .375	91
-	-	-	-	-	-	-	318563-1	GUARD, FRONT CHIP	89
-	-	-	-	-	-	-	4088040	SF APPL INST 408-8040	72
-	-	-	-	-	-	-	217238-1	GENERAL INSTRUCTION PKG	71
-	-	-	-	-	-	-	461264-5	PLATE, IDENTIFICATION	67
-	-	-	-	-	-	-	21017-2	SCREW, DRIVE	66
-	-	-	-	-	-	-	21009-2	SCR, SET, SELF LOCKING 1/4-20 X .250	63
-	-	-	-	-	-	-	22733-8	SCR, BHSC, SELF-LOCKING, 8-32 X .375	60
-	-	-	-	-	-	-	2-22603-0	SCR, HEX HD CAP 8-32 X .312	59
-	-	-	-	-	-	-	458537-2	PAWL, FEED	56
-	-	-	-	-	-	-	2-21002-2	SCR, BTN SKT HD CAP 8-32 X .500	54
-	-	-	-	-	-	-	2-21000-7	SCR, SKT HD CAP 8-32 X .500	53
-	-	-	-	-	-	-	21018-5	NUT, HEX, REG 6-32	52
-	-	-	-	-	-	-	811242-2	BUMPER, HOLD DOWN	51
-	-	-	-	-	-	-	690753-1	SPACER, TONKER	50
-	-	-	-	-	-	-	690602-6	CAM, PRE FEED, 1 5/8	49
-	-	-	-	-	-	-	690602-5	CAM, PRE FEED, 1 1/8	48
-	-	-	-	-	-	-	690501-4	CAM, POST-FEED 1 5/8	47
-	-	-	-	-	-	-	459456-1	APPL, BASIC SUB ASSY (SIDE WISE MOCA)	46
-	-	-	-	-	-	-	690191-1	PLUG, NYLON	45
-	-	-	-	-	-	-	819307-7	RAM, SIDE FEED	44
-	-	-	-	-	-	-	7-21002-9	SCR, BTN SKT HD CAP 5/16-24 X 1.00	41
-	-	-	-	-	-	-	690125-1	SHIM SUB-ASSY	39
-	-	-	-	-	-	-	469367-9	SHIM	38
-	-	-	-	-	-	-	879103-2	FINE ADJUST HEAD ASSEMBLY	37
-	-	-	-	-	-	-	690786-1	TERMINAL SUPPORT	34
-	-	-	-	-	-	-	2-21002-4	SCR, BTN SKT HD CAP 8-32 X .750	33
-	-	-	-	-	-	-	21024-5	WASHER, SPRG LOCK, REG NO 10	32
-	-	-	-	-	-	-	3-21000-4	SCR, SKT HD CAP 10-32 X .375	31
-	-	-	-	-	-	-	1320908-1	SPACER, STRIP GUIDE	30
-	-	-	-	-	-	-	1633091-1	ASSEMBLY, STRIP GUIDE	29
-	-	-	-	-	-	-	1-455888-0	SPACER, CRIMPER	28
-	-	-	-	-	-	-	1320928-1	PLATE, STRIP GUIDE	24
-	-	-	-	-	-	-	690472-2	STRIPPER	22
-	-	-	-	-	-	-	2-21000-7	SCR, SKT HD CAP 8-32 X .500	21
-	-	-	-	-	-	-	21024-4	WASHER, SPRG LOCK, REG NO 8	20
-	-	-	-	-	-	-	691353-1	STRIPPER	19
-	-	-	-	-	-	-	679625-1	SHEAR HOLDER, FRONT (NO CUT)	17
-	-	-	-	-	-	-	3-568176-2	CRIMPER, WIRE	15
-	-	-	-	-	-	-	3-22280-3	SPRING, COMPRESSION	12
-	-	-	-	-	-	-	690461-1	STOP, SHEAR	11
-	-	-	-	-	-	-	690459-1	SHEAR HOLDER, FRONT	10
-	-	-	-	-	-	-	454276-1	FLOATING SHEAR, FRONT	9
-	-	-	-	-	-	-	904132-4	ANVIL, COMBINATION	8
-	-	-	-	-	-	-	1-455889-4	DEPRESSOR, SHEAR	5
-	-	-	-	-	-	-	3-238011-1	BLOCK, CRIMPER SPACER	4
-	-	-	-	-	-	-	7-683453-6	CRIMPER, INSULATION PREMIUM	3
-	-	-	-	-	-	-	1-455888-1	SPACER, CRIMPER	2
-	-	-	-	-	-	-	3-568176-1	CRIMPER, WIRE	1

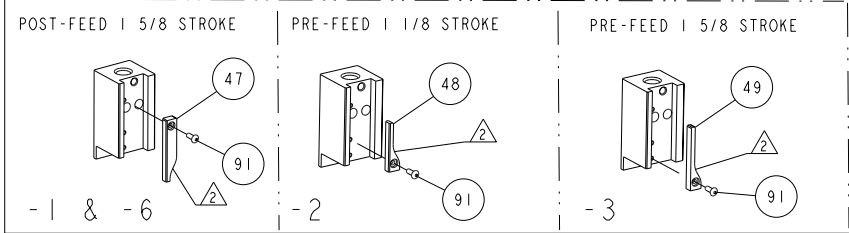

DIMENSIONS:		TOLERANCES UNLESS OTHERWISE SPECIFIED:		MATERIAL:		FINISH:	
INCHES	0 PLC #0.1	1 PLC #0.1	2 PLC #0.01	3 PLC #0.001	4 PLC #0.0001	ANGLES	±
APPLICATOR SPEC		APPLICATOR SPEC		APPLICATOR SPEC		APPLICATOR SPEC	
CUSTOMER ACCESSIBLE PRODUCTION DRAWING		SCALE 3:5		SHEET 1 OF 1		REV B	