

THIS DRAWING IS UNPUBLISHED. RELEASED FOR PUBLICATION
 © COPYRIGHT 64 BY TYCO ELECTRONICS CORPORATION. ALL INTERNATIONAL RIGHTS RESERVED.

LOC	DIST	REVISIONS			
P	LTR	DESCRIPTION	DATE	DWN	APVD
AF	50	AB	REVISED PER ECR-10-006099	07JUL10	HMR PD

1 CONTINUOUS STRIP ON REELS.

3 .000150 MIN NICKEL PLATE WITH LUBRICATE.

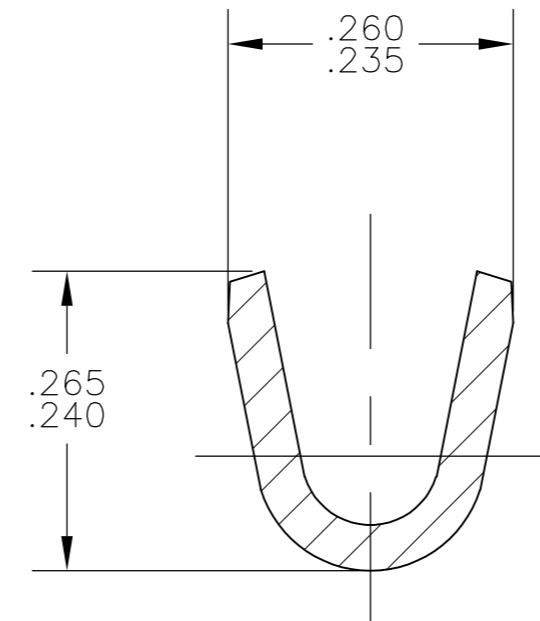
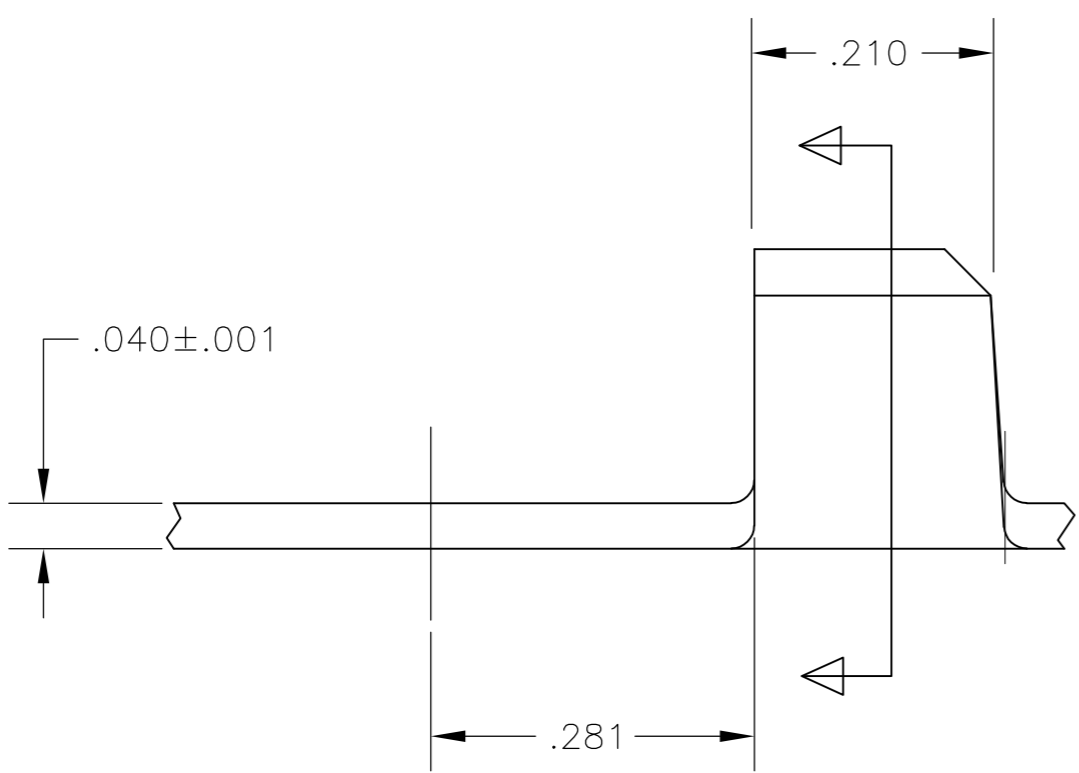
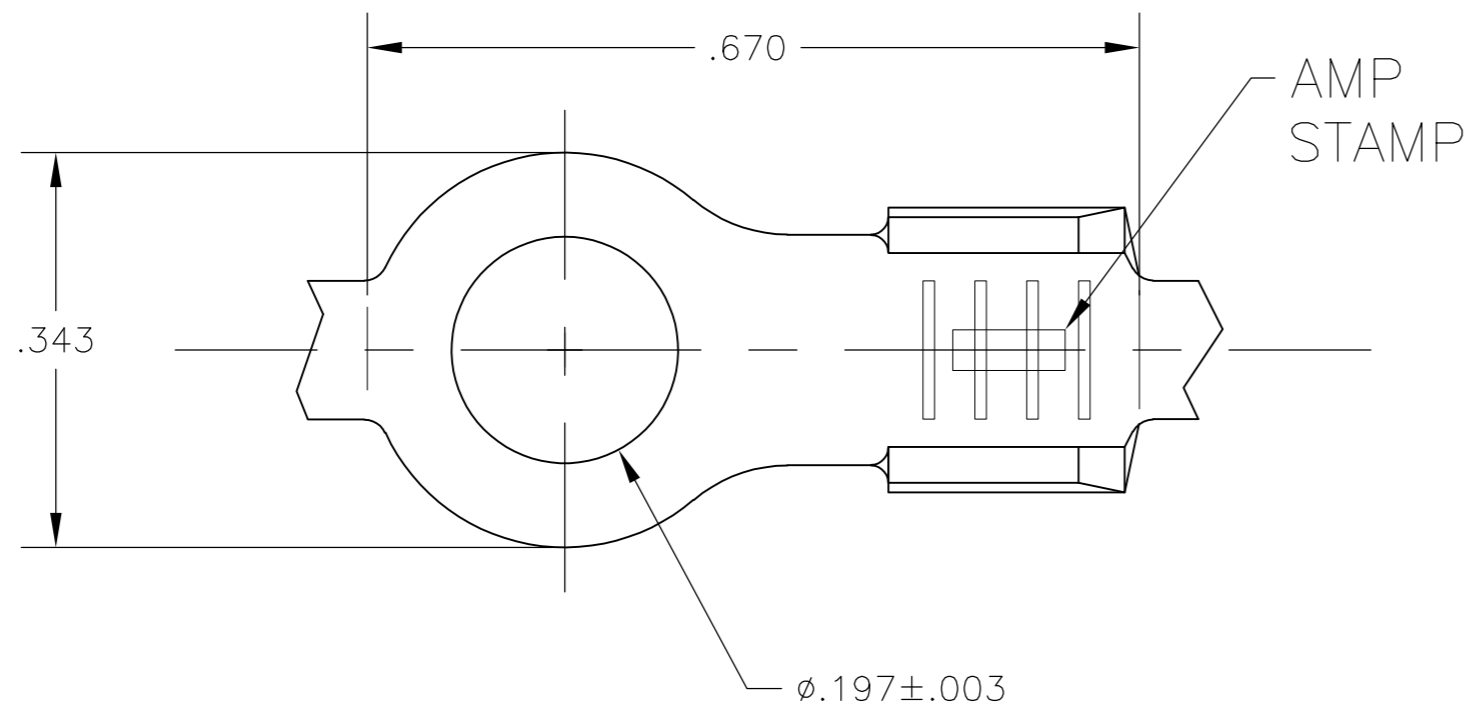

OBSOLETE	12-10 AWG	3	TEMPER 3 STEEL	41090-1
	12-10 AWG	TIN	H00 COPPER	41090
	WIRE RANGE	FINISH	MATERIAL	PART NUMBER

THIS DRAWING IS A CONTROLLED DOCUMENT.		DWN 14FEB2002 MICHAEL S. FEHER	Tyco Electronics Corporation Harrisburg, PA 17105-3608	
DIMENSIONS: INCHES	TOLERANCES UNLESS OTHERWISE SPECIFIED:	CHK 14FEB2002 DONALD F. DECKER	NAME TERMINAL, RING #10 STUD	
	0 PLC ± - 1 PLC ± - 2 PLC ± - 3 PLC ± .010 4 PLC ± - ANGLES ± 1°	APVD 14FEB2002 DONALD F. DECKER	SIZE A2	CAGE CODE 00779
MATERIAL SEE TABLE	FINISH SEE TABLE	PRODUCT SPEC -	DRAWING NO C=41090	RESTRICTED TO -
		APPLICATION SPEC -	WEIGHT -	SCALE 6:1
		WEIGHT -	CUSTOMER DRAWING	SHEET 1 of 1 REV AB