

THIS DOCUMENT IS THE PROPERTY OF
KEYSTONE ELECTRONICS CORP. AND
SHALL NOT BE REPRODUCED, DISTRIBUTED
OR USED AS A BASIS FOR MANUFACTURE
WITHOUT PRIOR WRITTEN PERMISSION
FROM KEYSTONE ELECTRONICS CORP.

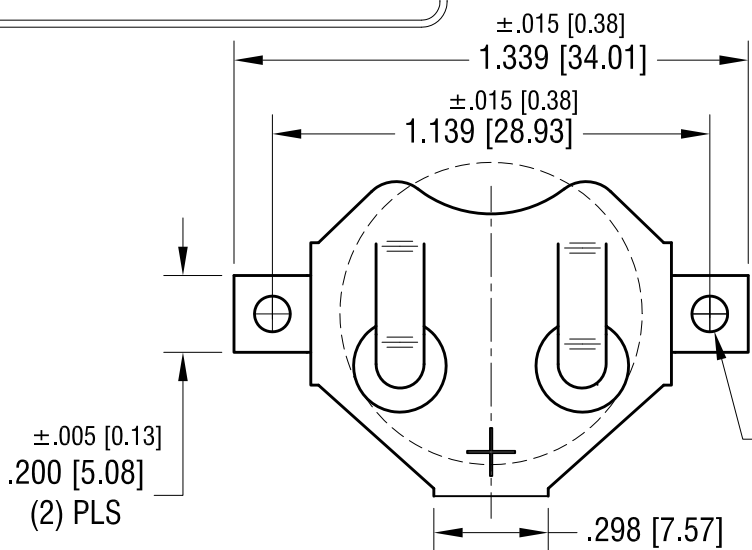

±.005 [0.13]
Ø.093 [Ø2.36] DIA.
(2) PLS

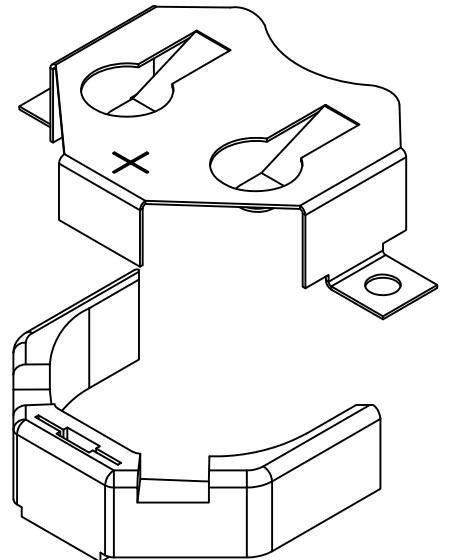
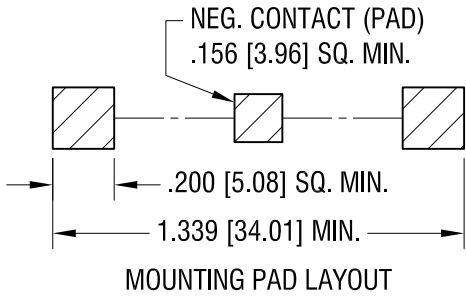
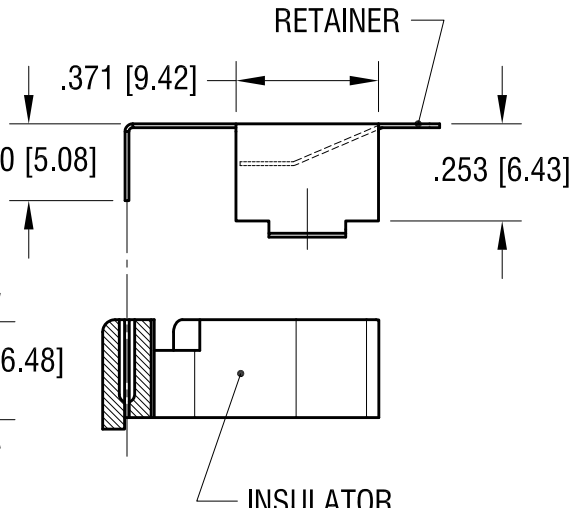
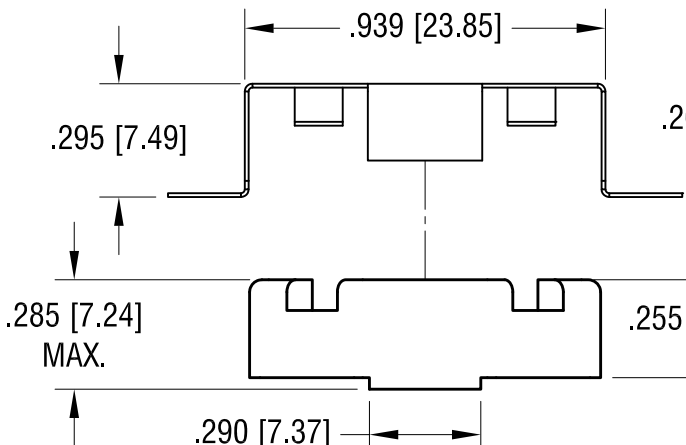

- NOTE:
1. CLIP MAT'L: .010 TH'K FULL HARD PHOSPHOR BRONZE
FINISH: MATTE TIN PLATE
 2. INSULATOR MAT'L: HIGH TEMPERATURE NYLON, UL 94V-0
COLOR: WHITE
 3. PARTS SUPPLIED UNASSEMBLED

KEYSTONE ELECTRONICS CORP.			
www.keyelco.com • ASTORIA, N.Y. 11105-2017 • Tel (718) 956-8900			
PART NAME			
SM COIN CELL CLIP FOR TWO 2032			
MATERIAL			
AS NOTED			
FINISH		DRN BY	DATE
AS NOTED		NT	10.15.10
		APP'D	SCALE
		LN	2X
TOLERANCES	INCH	[MM]	CODE
DECIMAL	± .010	[± 0.25]	C
ANGULAR	± 1°		DWG NO.
UNLESS OTHERWISE SPECIFIED			3074-2

DATE	DESCRIPTION	REV.