

THIS DRAWING IS UNPUBLISHED. RELEASED FOR PUBLICATION
 © COPYRIGHT - By - ALL RIGHTS RESERVED.

LOC	DIST	REVISIONS			
P	LTR	DESCRIPTION	DATE	DWN	APVD
AF	50	G	REVISED PER ECR-12-013518	23NOV2012	KH PD

- 1 CONTINUOUS STRIP ON REELS
- 2 ACCEPTS #18-#14 AWG WIRE SIZE CRIMP WIDTH, .120, F TYPE
- 3 INSULATION RANGE IS .120-.170 DIA CRIMP WIDTH, .180, F OR O TYPE
- 4 MATING TAB THK IS .032±.001.

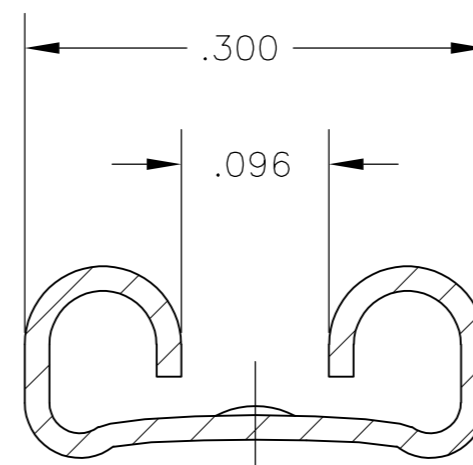
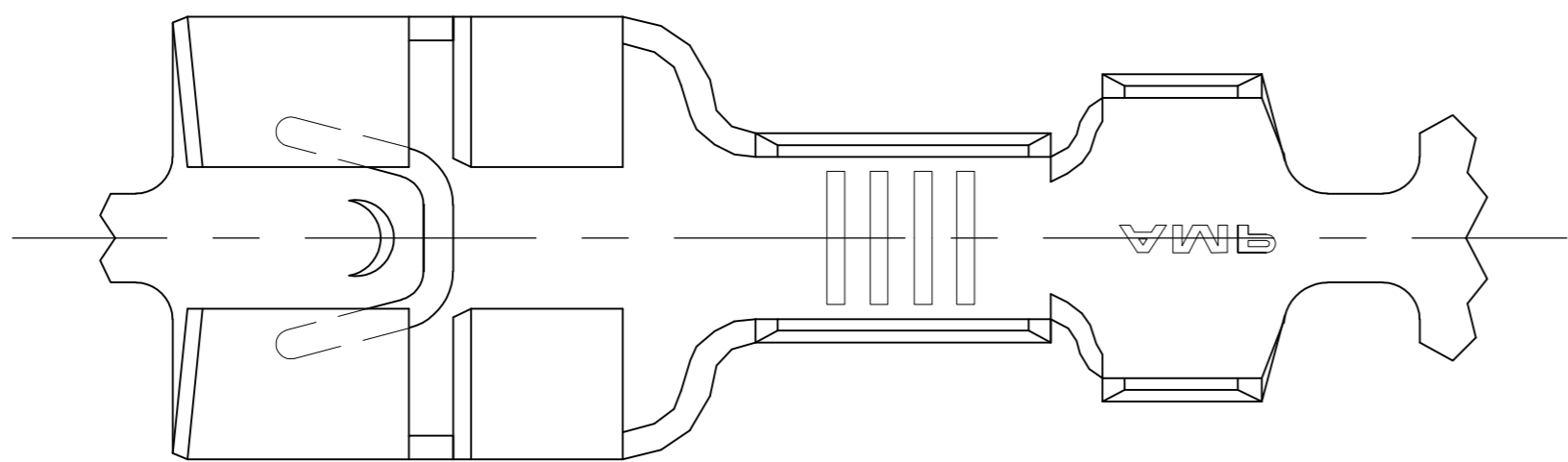

SECTION C-C

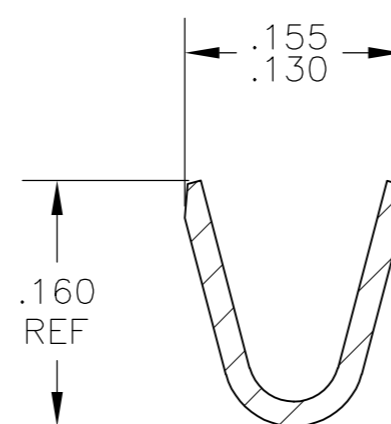
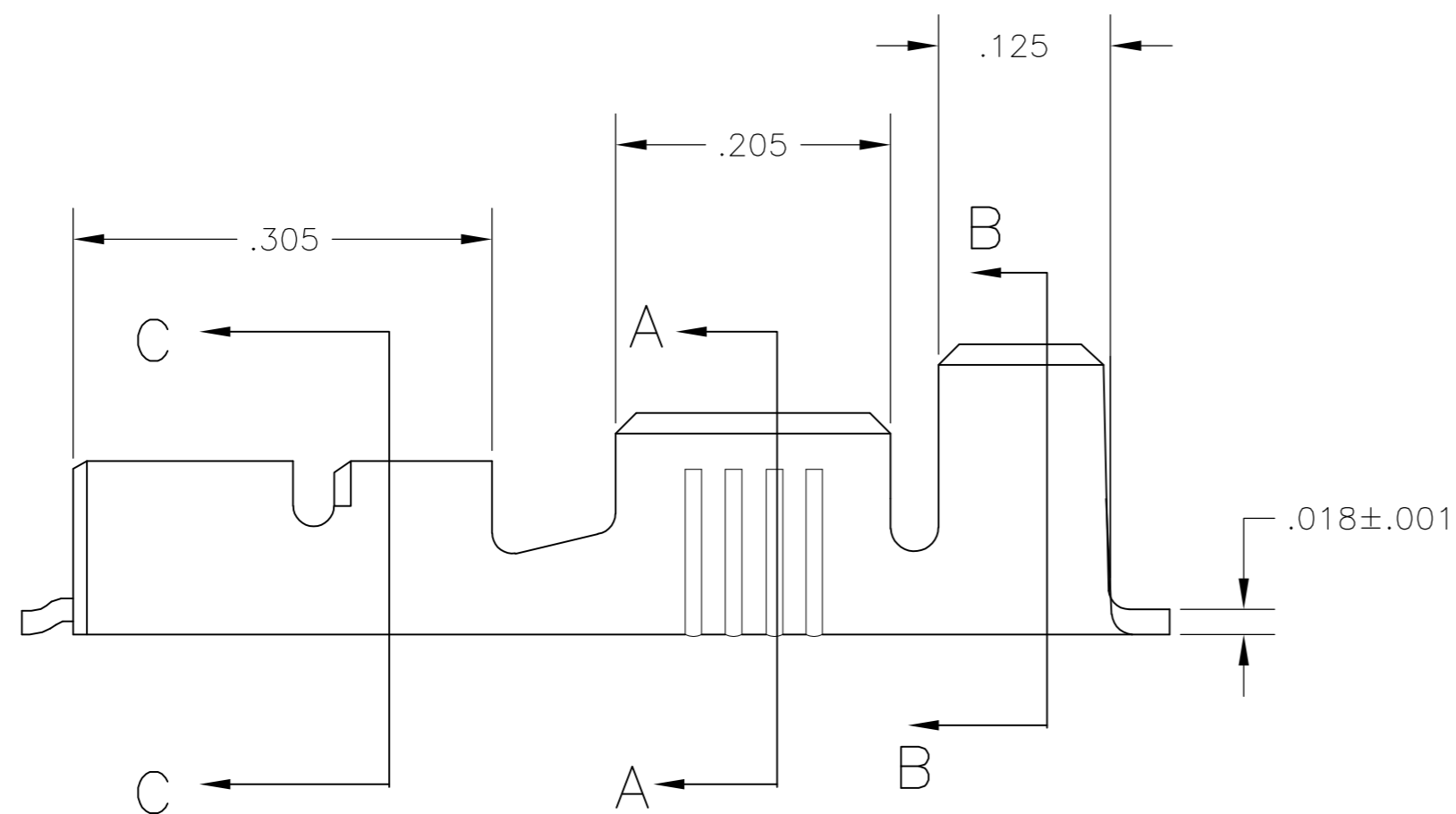

SECTION A-A

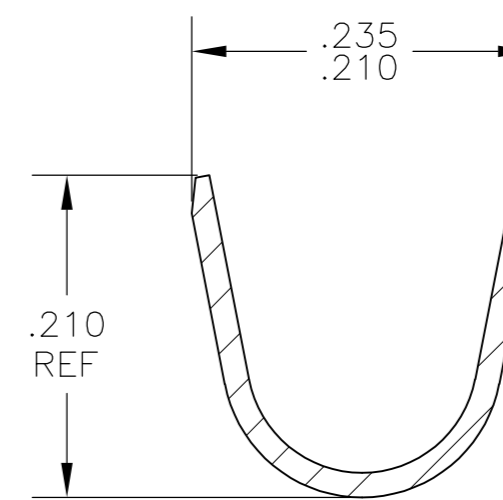

SECTION B-B

TIN	63537-2
-	63537-1
FINISH	PART NO

THIS DRAWING IS A CONTROLLED DOCUMENT.		DWN	JR RUTH	21JUN02		TE Connectivity																						
DIMENSIONS: INCHES		CHK	P DESANTIS	21JUN02		NAME																						
TOLERANCES UNLESS OTHERWISE SPECIFIED:		APVD	P DESANTIS	21JUN02		RECEPTACLE, FASTON, .250 SERIES																						
<table border="1"> <tr><td>0 PLC</td><td>±</td><td>-</td></tr> <tr><td>1 PLC</td><td>±</td><td>-</td></tr> <tr><td>2 PLC</td><td>±</td><td>-</td></tr> <tr><td>3 PLC</td><td>±</td><td>.010</td></tr> <tr><td>4 PLC</td><td>±</td><td>-</td></tr> <tr><td>ANGLES</td><td>±</td><td>-</td></tr> <tr><td>FINISH</td><td></td><td></td></tr> </table>		0 PLC	±	-		1 PLC	±	-	2 PLC	±	-	3 PLC	±	.010	4 PLC	±	-	ANGLES	±	-	FINISH			PRODUCT SPEC	-	SIZE	CAGE CODE	DRAWING NO
0 PLC	±	-																										
1 PLC	±	-																										
2 PLC	±	-																										
3 PLC	±	.010																										
4 PLC	±	-																										
ANGLES	±	-																										
FINISH																												
MATERIAL	BRASS	WEIGHT	-	A2	00779	C=63537	-																					
SEE TABLE		CUSTOMER DRAWING	SCALE	8:1	SHEET	1 of 1	REV	G																				