

THIS DRAWING IS UNPUBLISHED. RELEASED FOR PUBLICATION
 © COPYRIGHT - By - ALL RIGHTS RESERVED.

| LOC | | DIST | | REVISIONS | | | |
|-----|-----|-------------|---------------------------|-----------|------|-----|--|
| P | LTR | DESCRIPTION | DATE | DWN | APVD | | |
| FT | 4 | J1 | REVISED PER ECO-11-004917 | 11MAR11 | RK | HMR | |

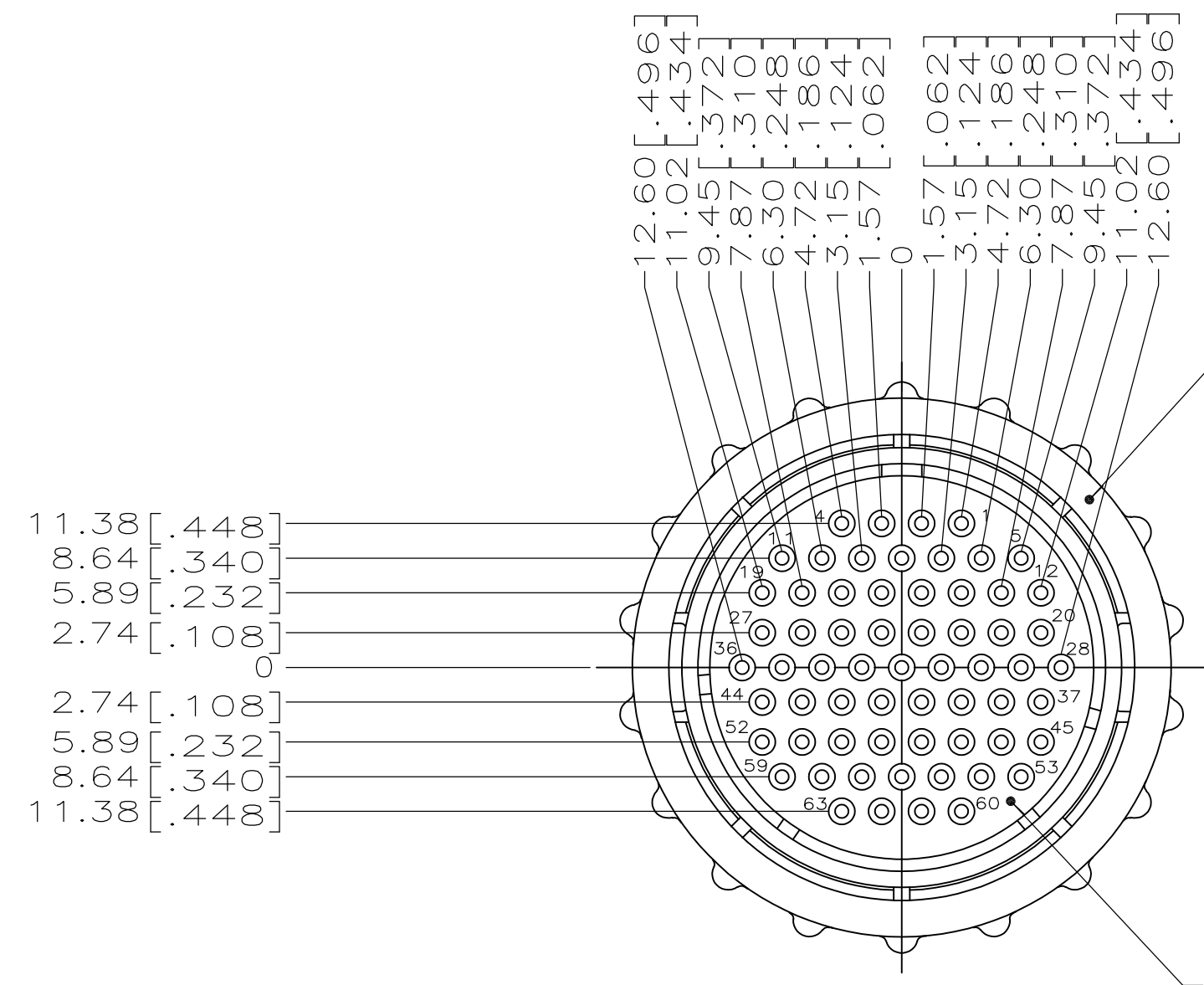

AMP AND PART NO THIS SURFACE

MATING FACE (-1 ONLY)

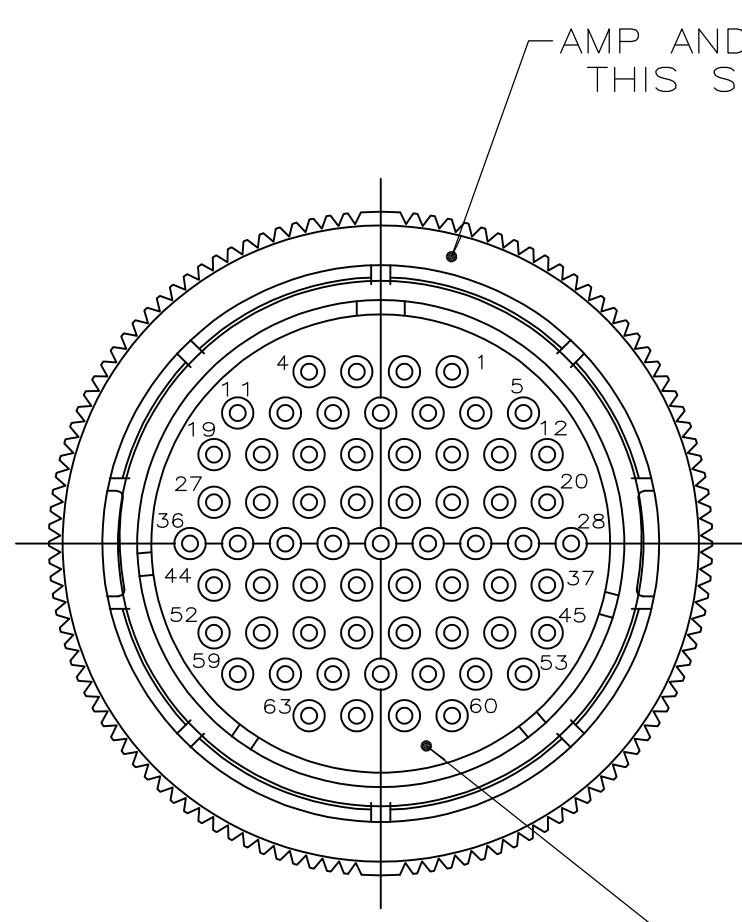

AMP AND PART NO THIS SURFACE

MATING FACE (-2 ONLY)

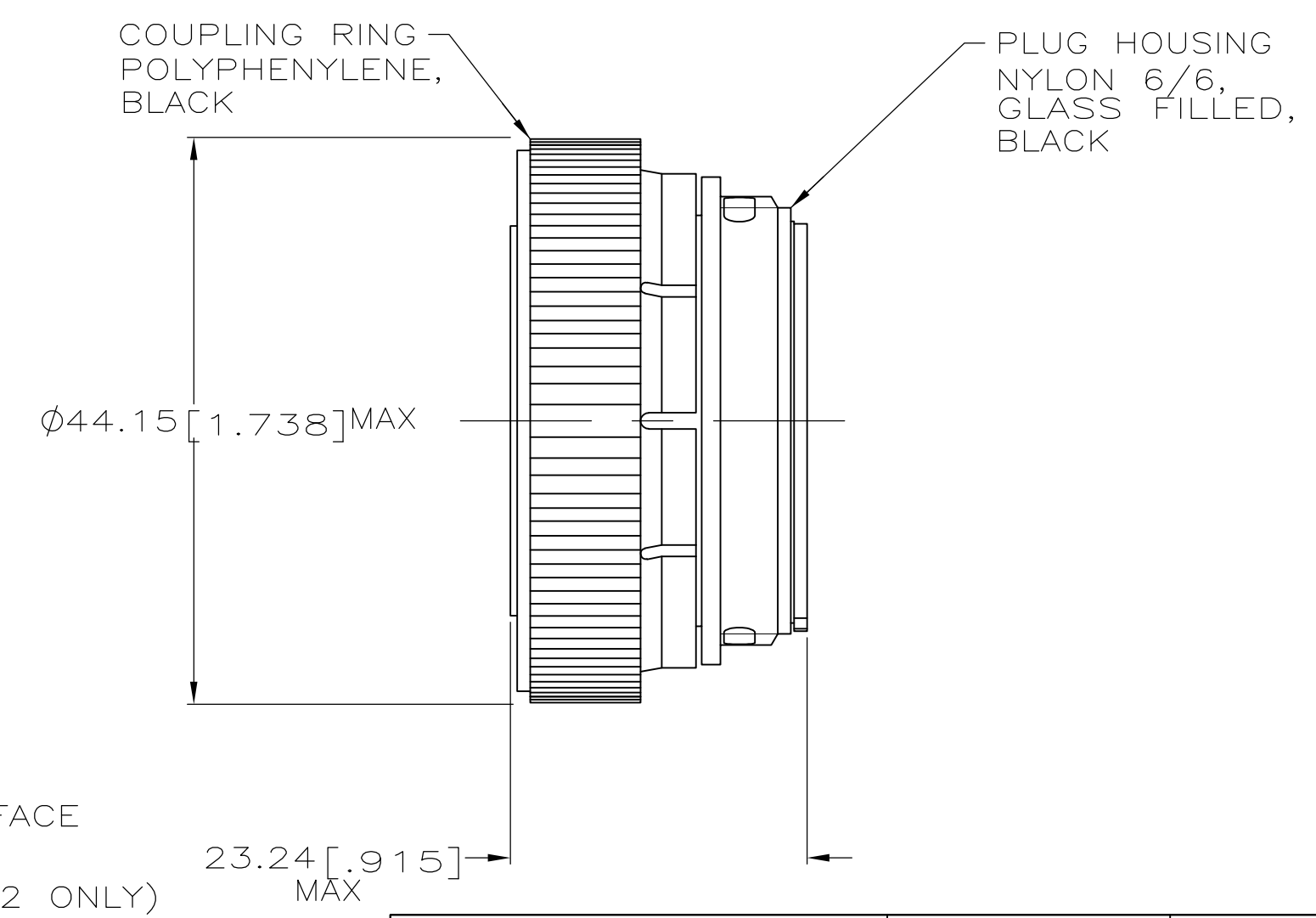
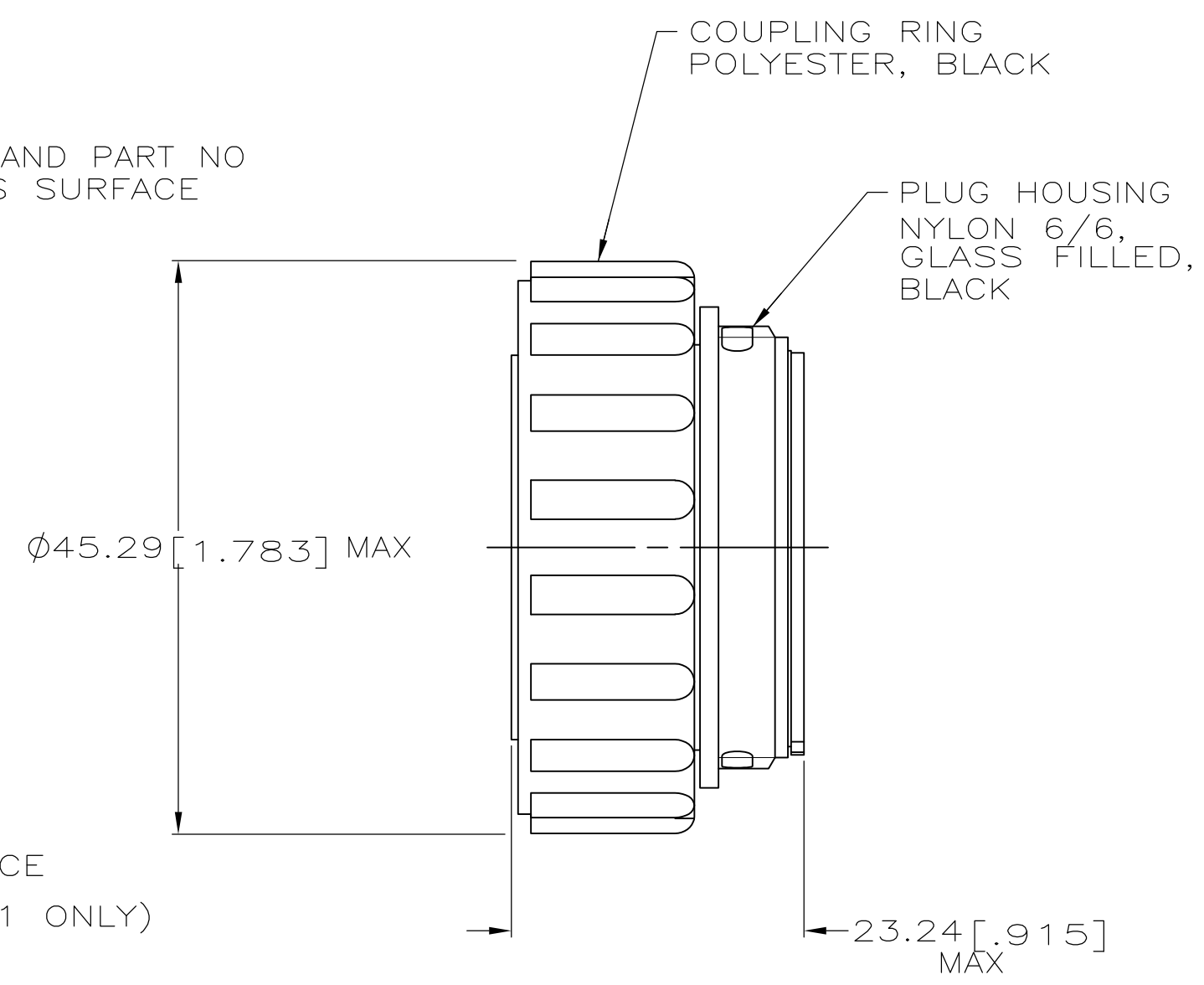

- CONTACT CAVITIES IDENTIFIED BY CHARACTERS ON FRONT AND REAR FACES OF CONNECTOR.
- WILL ACCEPT (63) SIZE 20 SOCKET CONTACTS.

205842-2
 205842-1
 PART NUMBER

| | | | | | | | | | | | | | | | | | |
|---|--|------------------|-------------|-----------|------|-----------------|-----------|-------|------------|----------|-------|-----|-------|--------|--------|-----|----|
| THIS DRAWING IS A CONTROLLED DOCUMENT. | | DWN | A. STAUB BG | 4 APR 91 | | TE Connectivity | | | | | | | | | | | |
| DIMENSIONS: mm [INCHES] | | CHK | W. LENKER | 23 JUL 92 | | NAME | | | | | | | | | | | |
| TOLERANCES UNLESS OTHERWISE SPECIFIED: | | APVD | K. BEAVER | 23 JUL 92 | | PRODUCT SPEC | | | | | | | | | | | |
| 0 PLC ± - 1 PLC ± - 2 PLC ± 0.13 [.005] 3 PLC ± - 4 PLC ± - ANGLES ± - FINISH - | | APPLICATION SPEC | | 108-10024 | | RESTRICTED TO | | | | | | | | | | | |
| MATERIAL SEE CALLOUTS | | WEIGHT | - | | SIZE | A2 | CAGE CODE | 00779 | DRAWING NO | C=205842 | SCALE | 2:1 | SHEET | 1 OF 1 | REV | J1 | |
| CUSTOMER DRAWING | | | | | | | | | | SCALE | | 2:1 | SHEET | | 1 OF 1 | REV | J1 |