

PART NUMBER	ITEM① BODY	ITEM② CONTACT	ITEM③ INSULATOR	ITEM④ END CAP
125-0692-111	BERYLLIUM COPPER GOLD PL .00005 MIN OVER NICKEL PL .00005 MIN OVER COPPER PL .00005 MIN	BERYLLIUM COPPER GOLD PL .00005 MIN OVER NICKEL PL .00005 MIN OVER COPPER PL .00005 MIN	TEFLON	BRASS GOLD PL .00001 MIN OVER NICKEL PL .00005 MIN OVER COPPER PL .00005 MIN

REV	ECO	DATE
001	ECO-16-0080	2016/06/24

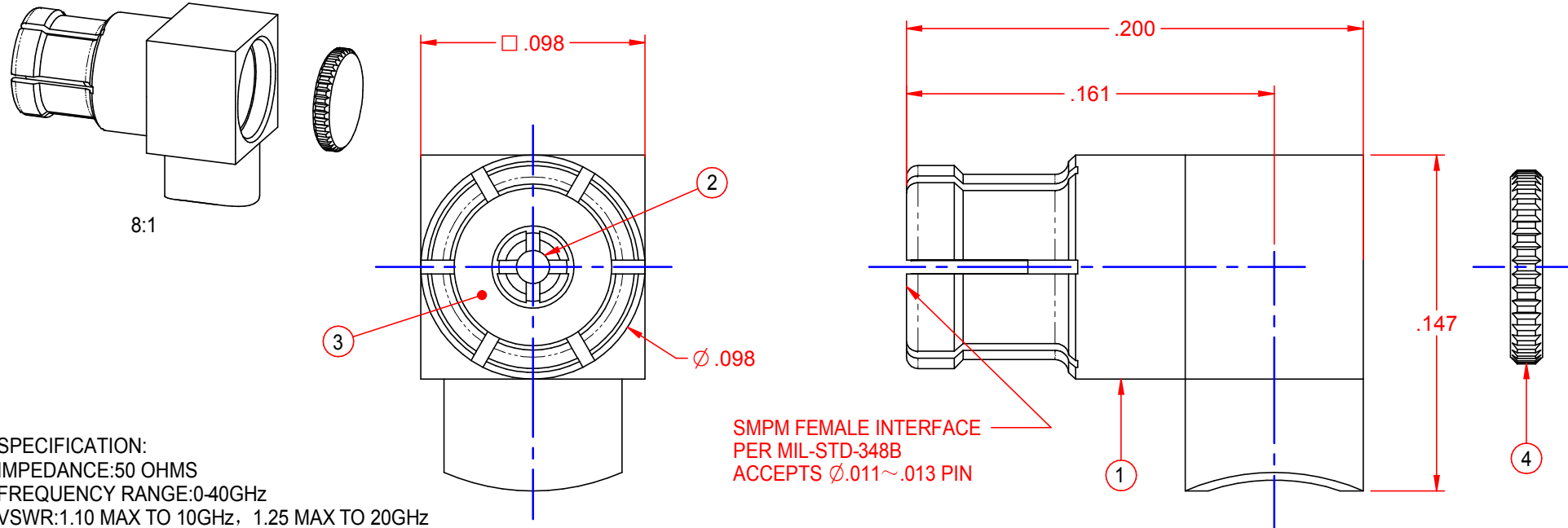

SPECIFICATION:
 IMPEDANCE:50 OHMS
 FREQUENCY RANGE:0-40GHz
 VSWR:1.10 MAX TO 10GHz, 1.25 MAX TO 20GHz
 INSERTION LOSS:0.12√F dB MAX (F IN GHz)
 DIELECTRIC WITHSTANDING VOLTAGE:325 VRMS MIN AT SEA LEVEL
 INSULATION RESISTANCE:5000 MEGOHM MIN
 CONTACT RESISTANCE:
 CENTER CONTACT - INITIAL 6 MILLIOHM MAX,AFTER ENVIRONMENTAL NOT APPLICABLE
 OUTER CONTACT - INITIAL 2 MILLIOHM MAX,AFTER ENVIRONMENTAL NOT APPLICABLE
 RF LEAKAGE:-80 dB TYPICAL AT 3GHz

MECHANICAL:
 ENGAGEMENT FORCE:FULL DETENT(FD) 4.5LBS TYPICAL;SMOOTH BORE(SB) 2.5LBS TYPICAL
 DISENGAGEMENT FORCE:FD 6.5LBS TYPICAL;SB 1.5LBS TYPICAL
 CONTACT RETENTION:1.5LBS MIN AXIAL FORCE
 DURABILITY:FD 100CYCLES MIN;SB 500 CYCLES MIN

ENVIRONMENTAL:
 OPERATING TEMPERATURE:-65°C TO 165°C
 THERMAL SHOCK:MIL-STD-202, METHOD 107, CONDITION B
 MECHANICAL SHOCK:MIL-STD-202, METHOD 213, CONDITION I
 CORROSION:MIL-STD-202, METHOD 101
 VIBRATION:MIL-STD-202, METHOD 204
 MOISTURE RESISTANCE:MIL-STD-202, METHOD 106, EXCEPT STEP 7B.

CABLE STRIP DIMENSION

 <small>This PROPRIETARY Document is property of Cinch Connectivity Solutions. It is confidential in nature, non-transferable, and issued with the clear understanding that it is not traced or copied without permission and is returnable upon demand.</small> <small>INTERPRET DRAWING IN ACCORDANCE WITH ASME Y14.5-2009.</small>	Model No. 125-0692-111	JOHNSON		
	RoHS2 2011/65/EU	Cage Code 14949	Title: SMPM FEMALE RIGHT ANGLE CABLED .047 SEMI-RIGID	
	UNLESS OTHERWISE SPECIFIED UNITS: INCH	3RD ANGLE PROJECTION	Drawing No. 125-0692-111	Rev. 001
	.XX ±.02 .XXX ±.005 ANGLES ±2°	Drawn by: Eric.Dai	Date: 2016/06/24	Size A
		DO NOT SCALE DRAWING	Workmanship Std. /	
			Sheet 1 of 1	