

THIS DRAWING IS UNPUBLISHED. RELEASED FOR PUBLICATION  
 BY AMP INCORPORATED. ALL RIGHTS RESERVED.

LOC	DIST	REVISIONS					
		P	LTR	DESCRIPTION	DATE	DWN	APVD
G	86	B		REVISED & REDRAWN PER 0720-0856-96	24JUN96	DKS	WJV

△ 1 STAMP AMP 600 MCM 1600/24 APPROX AS SHOWN

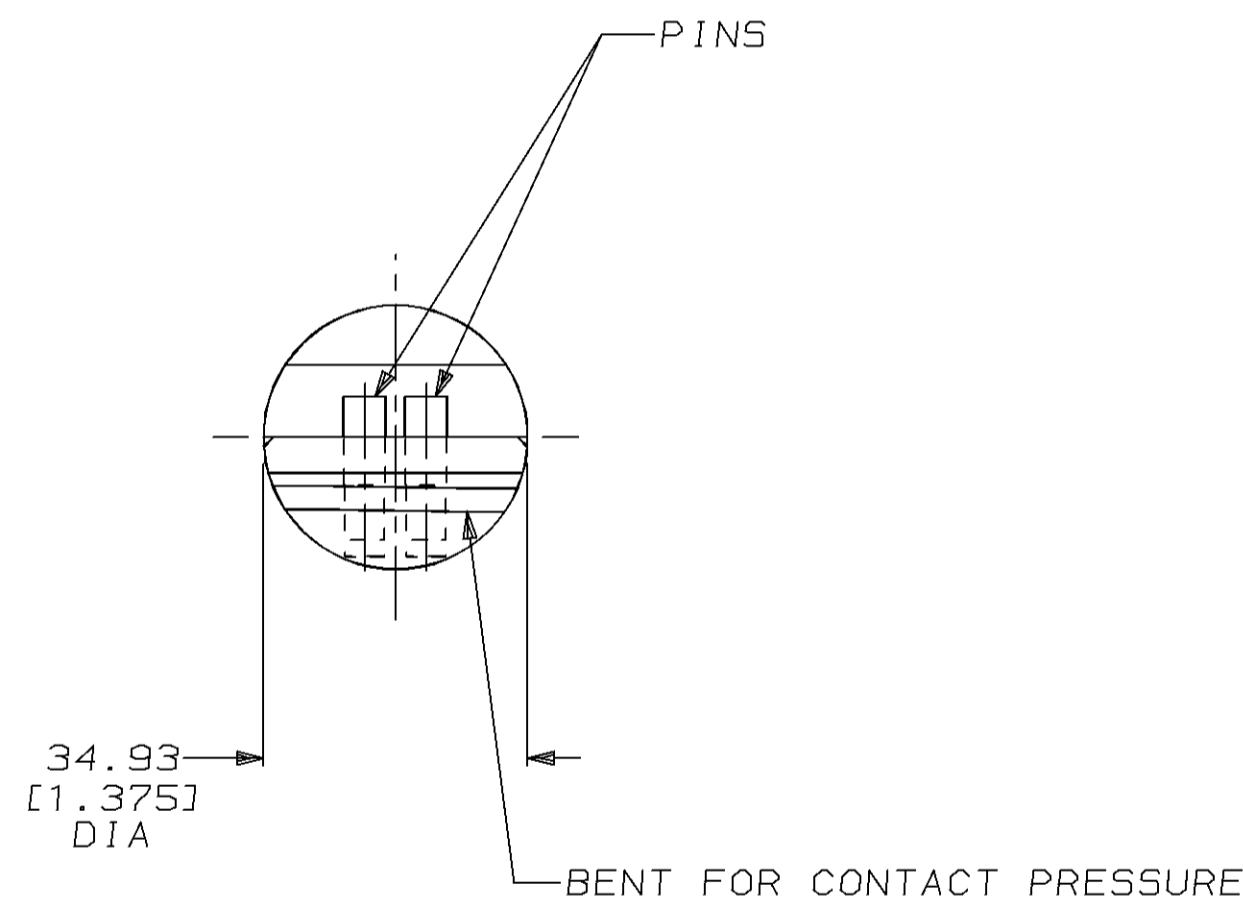
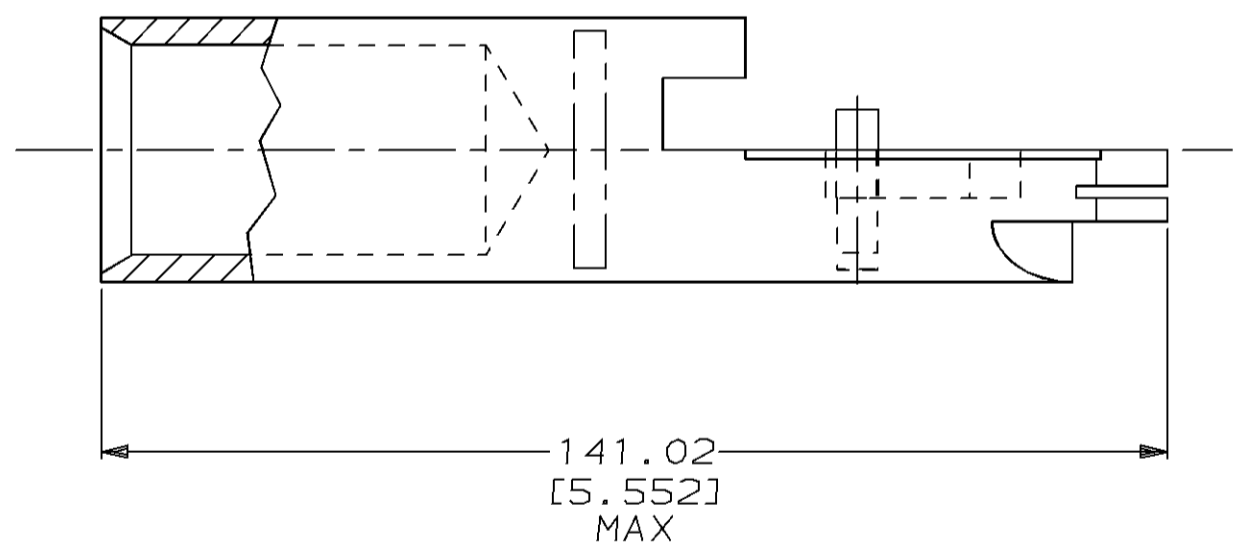
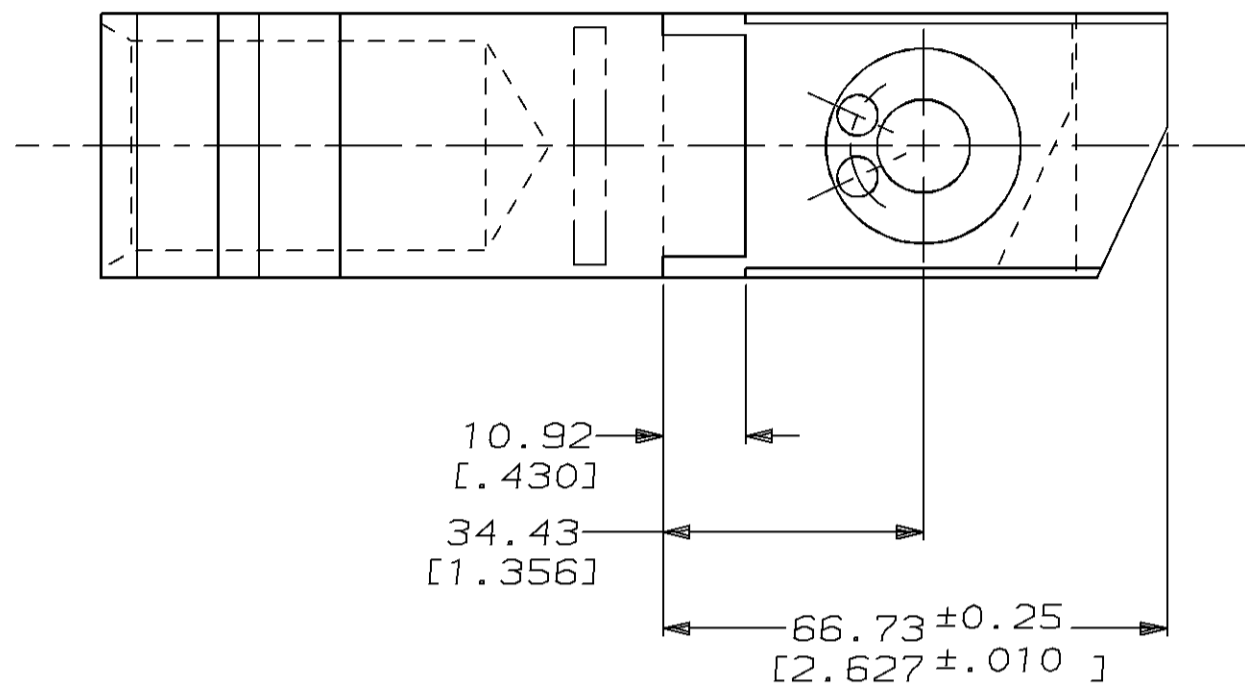

606713-1  
AMP  
PART NUMBER

<small>THIS DRAWING IS A CONTROLLED DOCUMENT FOR AMP INCORPORATED. IT IS SUBJECT TO CHANGE AND THE CONTROLLING ENGINEERING ORGANIZATION SHOULD BE CONTACTED FOR THE LATEST REVISION.</small>		DWN DK SCHRUM 24JUN96 CHK WJ VOCKROTH 25JUN96 APVD JL MECKLEY 25JUN96	<b>AMP</b> AMP Incorporated Harrisburg, PA 17105-3608
DIMENSIONS: mm [INCHES]	TOLERANCES UNLESS OTHERWISE SPECIFIED: 0 PLC ±- 1 PLC ±- 2 PLC ±0.20 [ .008 ] 3 PLC ±- 4 PLC ±- ANGLES ±-	PRODUCT SPEC 108-13014 APPLICATION SPEC -	NAME TERMINAL ASSEMBLY, QUICK-DISCONNECT, AMPPOWER, WIRE SIZE: 600 MCM
MATERIAL BODY & PINS BRASS PER QQ-B-626	FINISH SILVER PL 0.00127 [ .000050 ] MIN THK PER QQ-S-365	WEIGHT - lbs	SIZE A2 CAGE CODE 00779 DRAWING NO C=606713
CUSTOMER DRAWING			SCALE 1:1 SHEET 1 OF 1 REV B