

CODE NO.	CONTACT	A	B	C	D	E	F	G	H
CL683-0259-9-57	26	11.5	8.2	7.1	6	11.3	9.7	11.9	9.1
CL683-0274-2-57	30	12.5	9.2	8.1	7	12.3	10.7	12.9	10.1
CL683-0367-1-57	60	20	16.7	15.6	14.5	19.8	18.2	20.4	17.6
CL683-0399-8-57	70	22.5	19.2	18.1	17	22.3	20.7	22.9	20.1
CL683-0375-0-57	80	25	21.7	20.6	19.5	24.8	23.2	25.4	22.6

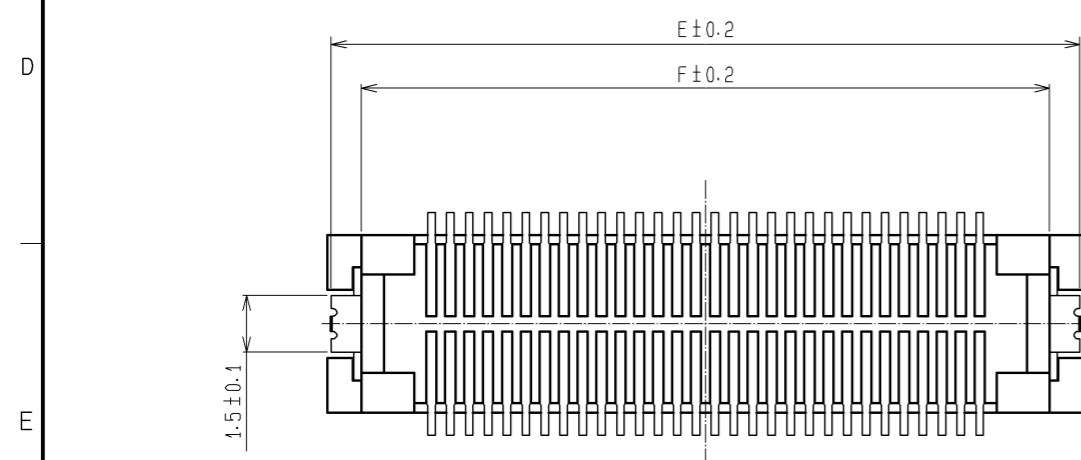

NOTES 1 : LEAD CO-PLANARITY INCLUDE REINFORCED METAL FITTINGS SHALL BE 0.1mm MAX.
 2 IF THE RESIST PROCESSING HAS NOT MADE, IT HAS POSSIBILITY THAT THE TERMINAL TOUCHES WITH AREA. PLEASE BE NOTED THIS POINT.

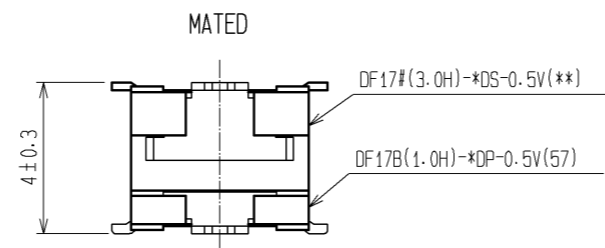

NO.	MATERIAL	FINISH . REMARKS	NO.	MATERIAL	FINISH . REMARKS
2	POLYAMIDE (PA6T)	WHITE BEIGE , UL94V-0	7	PS	CLEAR (REINFORCEMENT COLLAR)
1	PHOSPHER BRONZE	CONTACT AREA : GOLD PLATED 0.1μm min LEAD AREA : GOLD PLATED 0.02μm min UNDER PLATING : NICKEL 1μm min	6	PS	BLACK (PLASTIC REEL)
			5	POLYESTER	CLEAR (COVER TAPE)
			4	PS	CLEAR (EMBOSSED CARRIER TAPE)
			3	PHOSPHER BRONZE	TIN PLATED 1μm min UNDER PLATING : NICKEL 1μm min

UNITS	SCALE	COUNT	DESCRIPTION OF REVISIONS	DESIGNED	CHECKED	DATE
mm	5 : 1	2	DIS-H-007389	NT. SEKI	YH. MICHIDA	12. 11. 09

APPROVED	CHECKED	DESIGNED	DRAWN	DATE
KH. IKEDA	TS. MIYAZAKI	YH. MICHIDA	MS. SATO	11. 12. 17

DRAWING NO.	PART NO.	CODE NO.
EDC3-162767-77	DF17B(1.0H)-*DP-0.5V(57)	CL683-

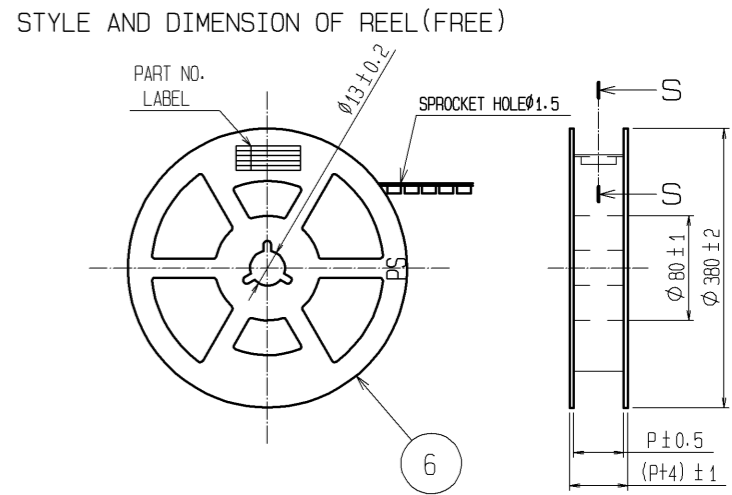
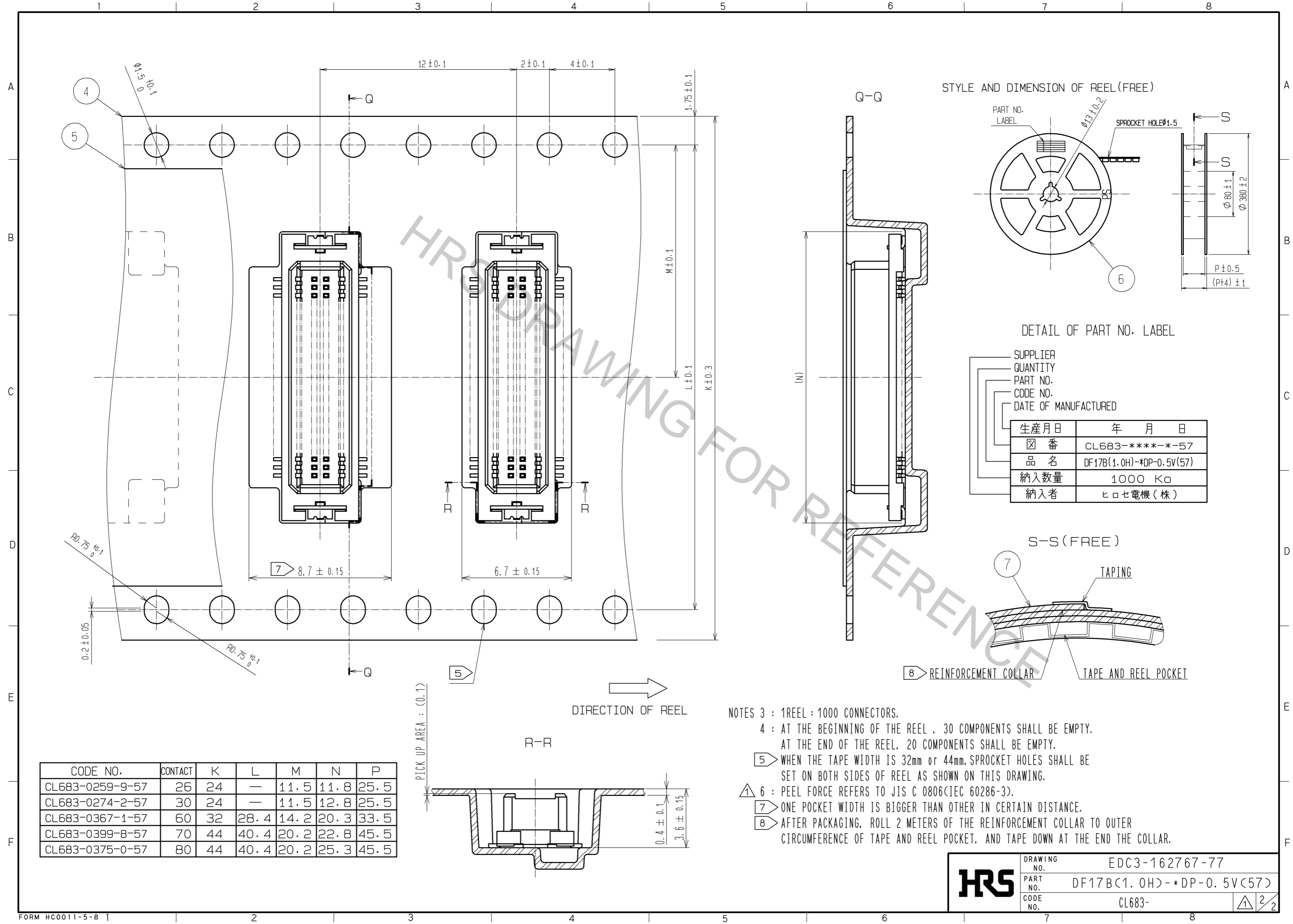

DETAIL OF PART NO. LABEL

SUPPLIER
 QUANTITY
 PART NO.
 CODE NO.
 DATE OF MANUFACTURED

生産月日	年 月 日
☒ 番	CL683-*****-57
品名	DF17B(1.0H)*DP-0.5V(57)
納入数量	1000 Ko
納入者	ヒロセ電機(株)

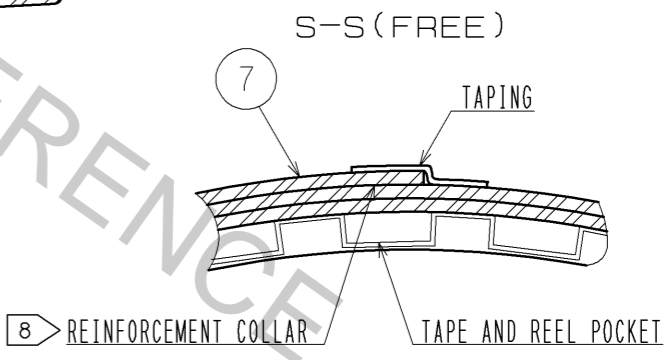

CODE NO.	CONTACT	K	L	M	N	P
CL683-0259-9-57	26	24	—	11.5	11.8	25.5
CL683-0274-2-57	30	24	—	11.5	12.8	25.5
CL683-0367-1-57	60	32	28.4	14.2	20.3	33.5
CL683-0399-8-57	70	44	40.4	20.2	22.8	45.5
CL683-0375-0-57	80	44	40.4	20.2	25.3	45.5

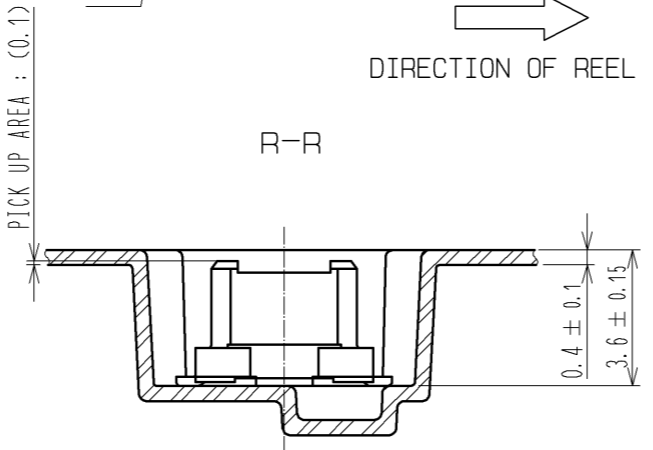

- NOTES 3 : 1 REEL : 1000 CONNECTORS.
 4 : AT THE BEGINNING OF THE REEL , 30 COMPONENTS SHALL BE EMPTY.
 AT THE END OF THE REEL, 20 COMPONENTS SHALL BE EMPTY.
 5 WHEN THE TAPE WIDTH IS 32mm or 44mm, SPROCKET HOLES SHALL BE SET ON BOTH SIDES OF REEL AS SHOWN ON THIS DRAWING.
 6 : PEEL FORCE REFERS TO JIS C 0806(IEC 60286-3).
 7 ONE POCKET WIDTH IS BIGGER THAN OTHER IN CERTAIN DISTANCE.
 8 AFTER PACKAGING, ROLL 2 METERS OF THE REINFORCEMENT COLLAR TO OUTER CIRCUMFERENCE OF TAPE AND REEL POCKET, AND TAPE DOWN AT THE END THE COLLAR.

HRS

DRAWING NO.	EDC3-162767-77
PART NO.	DF17B(1.0H)*DP-0.5V(57)
CODE NO.	CL683-

2/2