

MODEL ICM5 – THREE WAY ISOLATED SERIAL CONVERTER MODULE (RS-232C/RS-485)



- 9 PIN D-SUB CONNECTOR FOR RS-232 CONNECTION
- SWITCHABLE TERMINATION AND BIASING RESISTORS
- MODULAR RJ JACK OR SCREW TERMINAL FOR RS-485 CONNECTION

- ALLOWS COMMUNICATIONS BETWEEN RS-232 CONTROL EQUIPMENT AND PRODUCTS WITH RS-422/RS-485 SERIAL COMMUNICATIONS
- THREE WAY ISOLATION PROTECTS SERIAL EQUIPMENT FROM GROUND LOOPS (1000 VDC)
- AUTOMATIC RS-485 DRIVER CONTROL
- DIP SWITCH SELECTABLE BAUD RATES 9600, 19200, 38400, 57600, 115200
- WIDE DC INPUT POWER RANGE (+9 to 26 VDC)
- HALF DUPLEX (RS-485) AND FULL DUPLEX (RS-422)
- LED INDICATION FOR RXD, TXD, and POWER
- UNIVERSAL MOUNTING FOOT FOR DIN RAIL INSTALLATION
- SELECTABLE DTE & DCE OPERATION WORKS WITH ANY RS-232 CABLE



UL Recognized Component,
 File # E179259

DESCRIPTION

The ICM5 Serial Converter Module provides the capability of interfacing equipment with RS-485 serial communications to equipment with RS-232 communications while providing three way isolation. Data format of the RS-232 and RS-485 equipment must be the same.

The unit can be configured for full duplex (RS-422), or half duplex (RS-485) operation. In half duplex mode, the RS-485 driver is automatically enabled using the leading edge of the first character that is received on the RS-232 side. After the last character is received, the converter waits one character time (at the selected baud rate) to disable the RS-485 driver.

An external DC power source (+9 to 26 VDC) is required to power the ICM5. The external power source and RS-485 communications connections are made via a 7-position removable terminal block located on the front of the module. A modular RS-485 connector is also provided for fast and efficient connection to other Red Lion devices that use a modular connector. The RS-232 connection is provided via a standard D-SUB 9-pin male connector. The ICM5 can be configured for DTE or DCE operation, allowing the use of modem or null-modem cables.

There are 3 LEDs that can be viewed from the front of the converter module. A green power LED indicates power is on, a red RS-232 TXD LED flashes when the module is transmitting, and a green RS-232 RXD LED flashes when the module is receiving.

The unit is equipped with a universal mounting foot for attachment to standard DIN style mounting rails, including top hat profile rail according to EN 50 022 - 35x7.5 and 35x15, and G profile rail according to EN 50 035 - G32.

SAFETY SUMMARY

All safety related regulations, local codes and instructions that appear in the manual or on equipment must be observed to ensure personal safety and to prevent damage to either the instrument or equipment connected to it. If equipment is used in a manner not specified by the manufacturer, the protection provided by the equipment may be impaired.

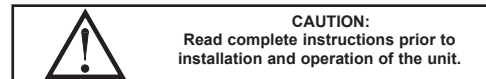

SPECIFICATIONS

- POWER:** +9 to 26 VDC @ 125 mA maximum. 85 mA typical
 Power Supply must be Class 2 or SELV rated.
- RS-232 VOLTAGES:**
Receive Data Pin: ± 30 VDC max.
Mark Condition: ≤ 0.8 VDC
Space Condition: ≥ 2.4 VDC
Transmit Data Pin:
Mark Condition: -8 VDC (typ.)
Space Condition: +8 VDC (typ.)
- RS-485 VOLTAGES:**
Differential Output Voltage: ± 5 VDC max. under no load
Differential Input Voltage: ± 5 VDC max.
Mark Condition: ≤ -0.2 VDC
Space Condition: ≥ +0.2 VDC
RS-485 Drive Capability: Up to 32 RS-485 receivers connected in parallel
RS-485 Drive Disable Time: one character time (at the set baud rate)
- MAXIMUM CABLE LENGTH:**
RS-232: 50 feet (15.24 m)
RS-485: 4000 feet (1219.2 m)
- BAUD RATE:** 9600 min., 115200 max.
- ISOLATION:** 1000 VDC
- ENVIRONMENTAL CONDITIONS:**
Operating Temperature Range: 0 to 50°C.
Storage Temperature: -40 to + 75°C
Operating and Storage Humidity: 85% max. relative humidity (non-condensing) from 0 to 50°C

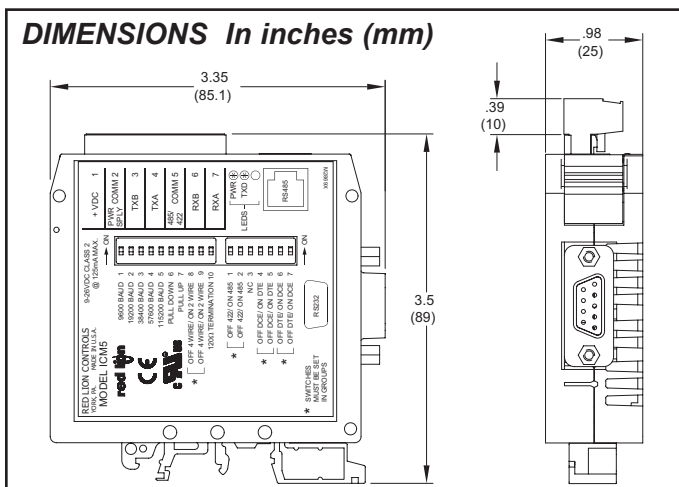

Vibration to IEC 68-2-6: Operational 5 to 150 Hz, 2 g.

Shock to IEC 68-2-27: Operational 30 g.

Altitude: Up to 2000 meters

8. CERTIFICATIONS AND COMPLIANCES:

SAFETY

UL Recognized Component, File #E179259

Recognized to U.S. and Canadian requirements under the Component Recognition Program of Underwriters Laboratories, Inc.

IEC 61010-1, EN 61010-1: Safety requirements for electrical equipment for measurement, control, and laboratory use, Part 1.

ELECTROMAGNETIC COMPATIBILITY

Immunity to EN 50082-2

Electrostatic discharge	EN 61000-4-2	Level 2; 4 Kv contact ¹ Level 3; 8 Kv air ¹
Electromagnetic RF fields	EN 61000-4-3	Level 3; 10 V/m 80 MHz - 1 GHz
Fast transients (burst)	EN 61000-4-4	Level 4; 2 Kv I/O Level 3; 2 Kv power
RF conducted interference	EN 61000-4-6	Level 3; 10 V/rms 150 KHz - 80 MHz

Emissions to EN 50081-1

RF interference

EN 55022 Enclosure class B

Power mains class B

Note:

- This device was designed for installation in an enclosure. To avoid electrostatic discharge to the unit in environments with static levels above 4 Kv, precautions should be taken when the device is mounted outside an enclosure. When working in an enclosure, (ex. making adjustments, setting switches etc.) typical anti-static precautions should be observed before touching the unit.

Refer to EMC Installation Guidelines for additional information.

- CONSTRUCTION: Case body is black, high impact plastic. Installation Category I, Pollution Degree 2.

- Mounting: Standard DIN rail top hat (T) profile rail according to EN50022- 35 X 7.5 and 35 X 15

- WEIGHT: 3.3 oz. (93.6 g)

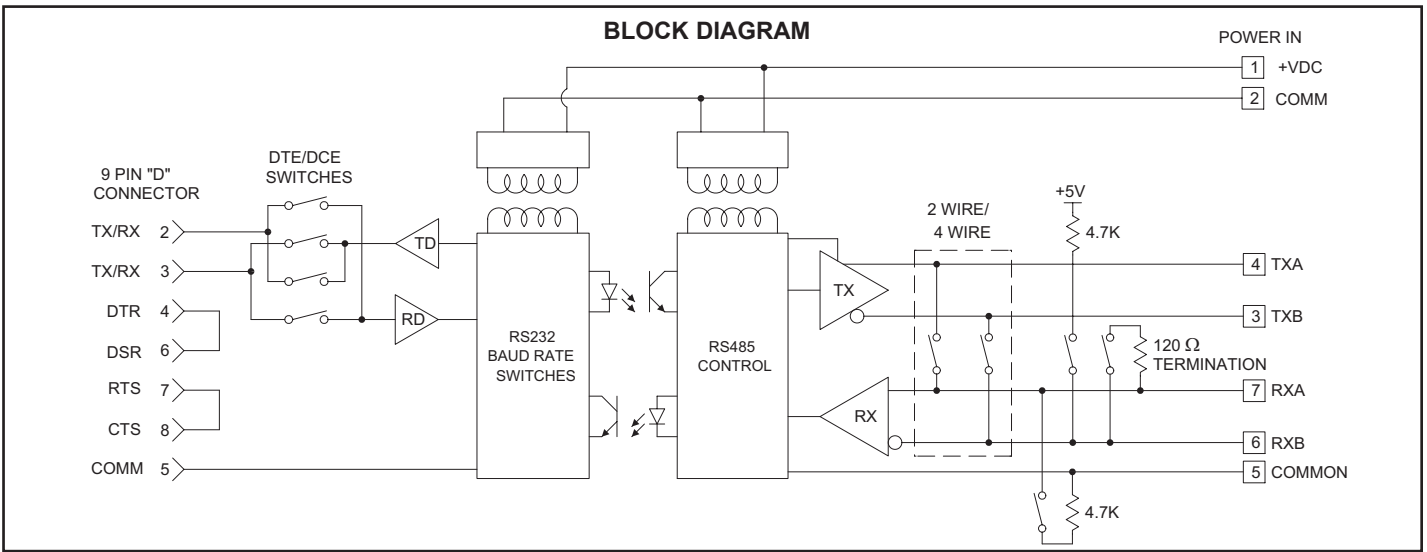

EMC INSTALLATION GUIDELINES

Although Red Lion Controls Products are designed with a high degree of immunity to Electromagnetic Interference (EMI), proper installation and wiring methods must be followed to ensure compatibility in each application. The type of the electrical noise, source or coupling method into a unit may be different for various installations. Cable length, routing, and shield termination are very important and can mean the difference between a successful or troublesome installation. Listed are some EMI guidelines for a successful installation in an industrial environment.

- A unit should be mounted in a metal enclosure, which is properly connected to protective earth.
- Use shielded cables for all Signal and Control inputs. The shield connection should be made as short as possible. The connection point for the shield depends somewhat upon the application. Listed below are the recommended methods of connecting the shield, in order of their effectiveness.
 - Connect the shield to earth ground (protective earth) at one end where the unit is mounted.
 - Connect the shield to earth ground at both ends of the cable, usually when the noise source frequency is over 1 MHz.
- Never run Signal or Control cables in the same conduit or raceway with AC power lines, conductors, feeding motors, solenoids, SCR controls, and heaters, etc. The cables should be run through metal conduit that is properly grounded. This is especially useful in applications where cable runs are long and portable two-way radios are used in close proximity or if the installation is near a commercial radio transmitter. Also, Signal or Control cables within an enclosure should be routed as far away as possible from contactors, control relays, transformers, and other noisy components.
- Long cable runs are more susceptible to EMI pickup than short cable runs.
- In extremely high EMI environments, the use of external EMI suppression devices such as Ferrite Suppression Cores for signal and control cables is

effective. The following EMI suppression devices (or equivalent) are recommended:

Fair-Rite part number 0443167251 (RLC part number FCOR0000)

Line Filters for input power cables:

Schaffner # FN2010-1/07 (Red Lion Controls # LFIL0000)

- To protect relay contacts that control inductive loads and to minimize radiated and conducted noise (EMI), some type of contact protection network is normally installed across the load, the contacts or both. The most effective location is across the load.

- Using a snubber, which is a resistor-capacitor (RC) network or metal oxide varistor (MOV) across an AC inductive load is very effective at reducing EMI and increasing relay contact life.
- If a DC inductive load (such as a DC relay coil) is controlled by a transistor switch, care must be taken not to exceed the breakdown voltage of the transistor when the load is switched. One of the most effective ways is to place a diode across the inductive load. Most RLC products with solid state outputs have internal zener diode protection. However external diode protection at the load is always a good design practice to limit EMI. Although the use of a snubber or varistor could be used.

RLC part numbers: Snubber: SNUB0000

Varistor: ILS11500 or ILS23000

- Care should be taken when connecting input and output devices to the instrument. When a separate input and output common is provided, they should not be mixed. Therefore a sensor common should NOT be connected to an output common. This would cause EMI on the sensitive input common, which could affect the instrument's operation.

Visit RLC's web site at <http://www.redlion.net/Support/InstallationConsiderations.html> for more information on EMI guidelines, Safety and CE issues as they relate to Red Lion Controls products.

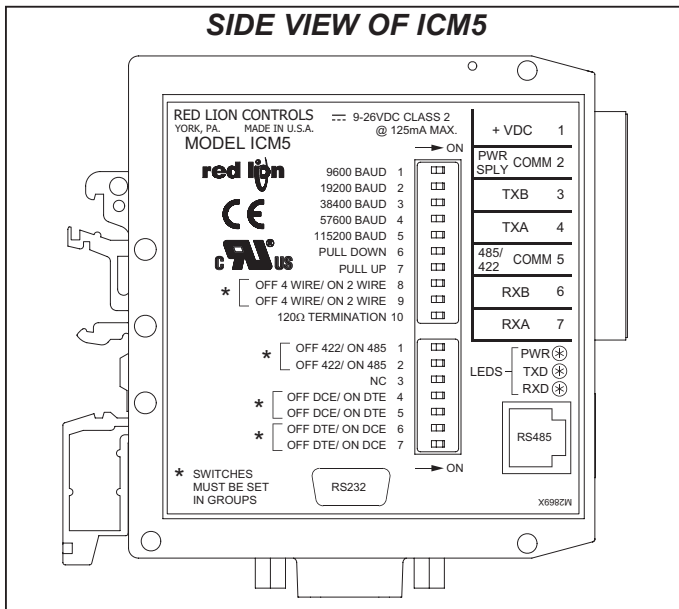

DIP SWITCH SETTINGS

Top Bank of 10 Switches

Switches 1-5 - BAUD

Select the appropriate baud rate. This adjusts the time delay for the automatic RS-485 driver controller. Only one of the baud switches should be in the ON position.

Switches 6-7 - PULL UP / PULL DOWN

These switches connect 4.7 K Ω biasing resistors to the A and B lines of the 485 receiver. To minimize loading of the network, these should only be used if no other device in the system provides biasing.

Switches 8-9 - OFF 4 WIRE / ON 2 WIRE

These switches can be used to internally jumper the A and B lines of the RS-485 driver and receiver together. This allows 2-wire operation without the use of external jumper wires. To use the RJ-11 connector, the ICM5 must be in 2-wire mode. Both switches should be in the same position.

Switch 10 - 120 Ω TERMINATION

This switch connects a 120 Ω resistor across the A and B lines of the RS-485 receiver. The use of the resistor prevents signal reflection, or echoing, at high baud rates, over long distances. This should only be turned on if the ICM5 is the first, or last, device in a multi-drop network that is experiencing reflection due to long cable distances.

Bottom Bank of 7 Switches

Switches 1-2 - OFF 422 / ON 485

These switches enable and disable the automatic RS-485 driver control. In the 422 position, the driver is always enabled, allowing 4-wire full duplex operation. In the 485 position, the driver is enabled as soon as characters are received on the RS-232 side. When the RS-485 driver has transmitted the last character, it waits one character time (at the selected baud rate), and then enters a high-impedance state. The receiver is also enabled and disabled in a similar fashion to prevent transmitted characters from being echoed back. This allows 2-wire, half-duplex operation, without the use of handshake lines. Both switches should be in the same position.

Switch 3 - N/C

No Connection

Switches 4-7 - OFF DCE / ON DTE

These switches configure the RS-232 port to act as a DCE or DTE device. With all of the switches in the DCE position, pin 2 of the DB-9 connector is the RS-232 receiver, and pin 3 is the RS-232 transmitter. DTE configures pin 2 as the transmitter, and pin 3 as the receiver. These switches allow the use of modem or null-modem cables. All of these switches should be in the DCE or DTE position. No other combinations are valid.

DEFAULT SETTINGS

BAUD RATE 9600
DCE
2 WIRE \ RS-485
NO TERMINATION
NO PULL-UP OR PULL DOWN

TYPICAL RS-232 CONNECTIONS

DCE

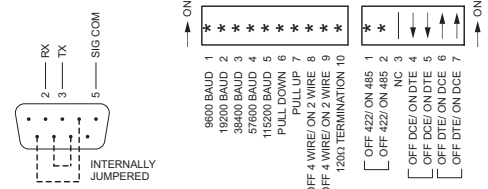

Note:

Connect shield (drain wire) to earth ground.

* - Application Dependent

DTE

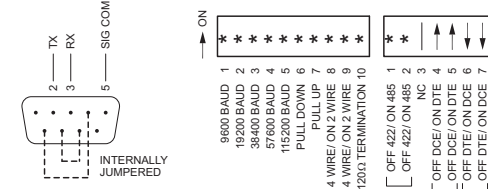

Note:

Connect shield (drain wire) to earth ground.

* - Application Dependent

TYPICAL RS-422 CONNECTIONS

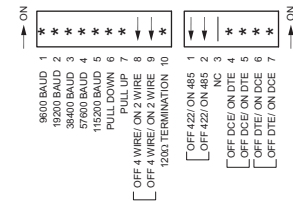
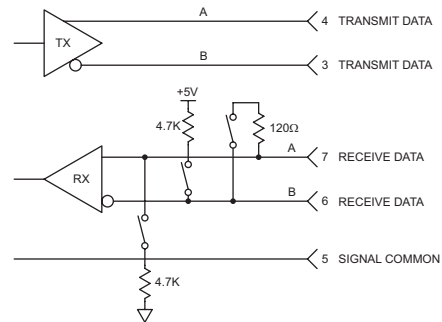

* - Application Dependent

Notes:

1. Connect shield (drain wire) to earth ground.
2. RS-422 polarity: Terminal "A" is negative with respect to Terminal "B" in the mark (logic 1) condition.

TYPICAL RS-485 CONNECTIONS

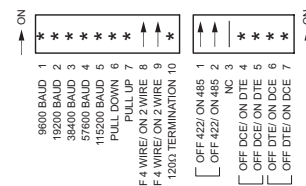
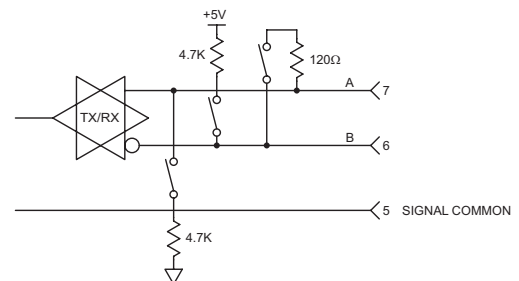

Note:

Connect shield (drain wire) to earth ground.

* - Application Dependent

TYPICAL CONNECTION FOR RS-485 DEVICES

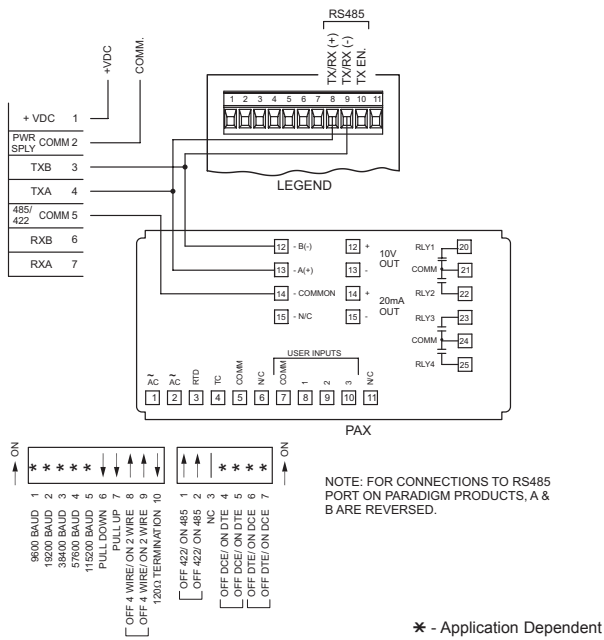

TYPICAL RS-485 CONNECTIONS USING RJ-11

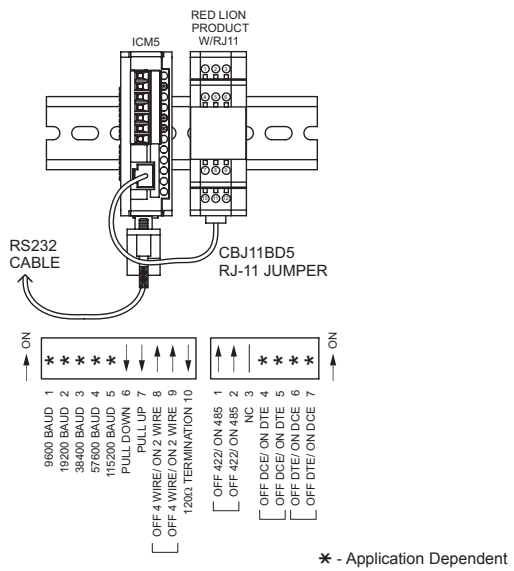

INSTALLATION

The unit is equipped with a universal mounting foot for attachment to standard DIN style mounting rails, including G profile rail according to EN50035 - G32, and top hat (T) profile rail according to EN50022 - 35 x 7.5 and 35 x 15. The unit should be installed in a location that does not exceed the maximum operating temperature and provides good air circulation. Placing the unit near devices that generate excessive heat should be avoided.

G Rail Installation

To install the ICM5 on a "G" style DIN rail, angle the module so that the upper groove of the "foot" catches under the lip of the top rail. Push the module toward the rail until it snaps into place. To remove a module from the rail, push up on the bottom of the module while pulling out away from the rail.

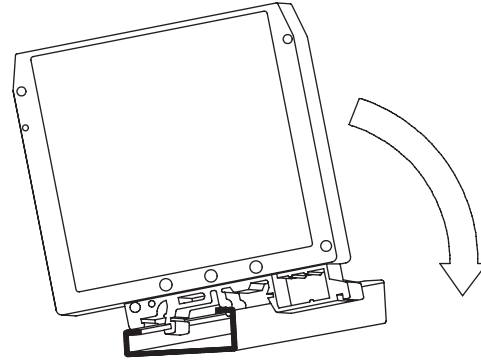

T Rail Installation

To install the ICM5 on a "T" style rail, angle the module so that the top groove of the "foot" is located over the lip of the top rail. Push the module toward the rail until it snaps into place. To remove a module from the rail, insert a screwdriver into the slot on the bottom of the "foot", and pry upwards on the module until it releases from the rail.

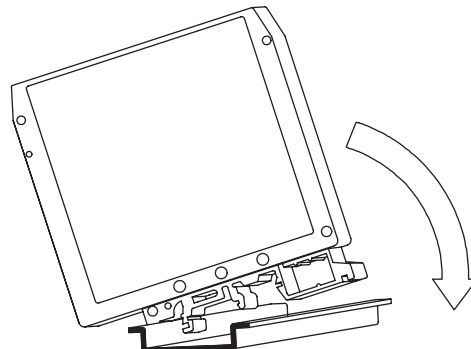

ORDERING INFORMATION

MODEL NO.	DESCRIPTION	PART NUMBER
ICM5	RS-232/RS-485 Converter Module	ICM50000
CBJ	6" RJ-11 Jumper Cable	CBJ11BD5

TROUBLESHOOTING

For further technical assistance, contact technical support at the appropriate company numbers listed.