

THIS DRAWING IS UNPUBLISHED. RELEASED FOR PUBLICATION, 19 .
 © COPYRIGHT 19 BY AMP INCORPORATED. ALL INTERNATIONAL RIGHTS RESERVED.

LOC	DIST	P	F	ZONE	LTR	REVISIONS	DATE	APPD
AF	50				K	REV AND REDRAWN PER 0710-0330-95	12/SEP/95	PF/GY

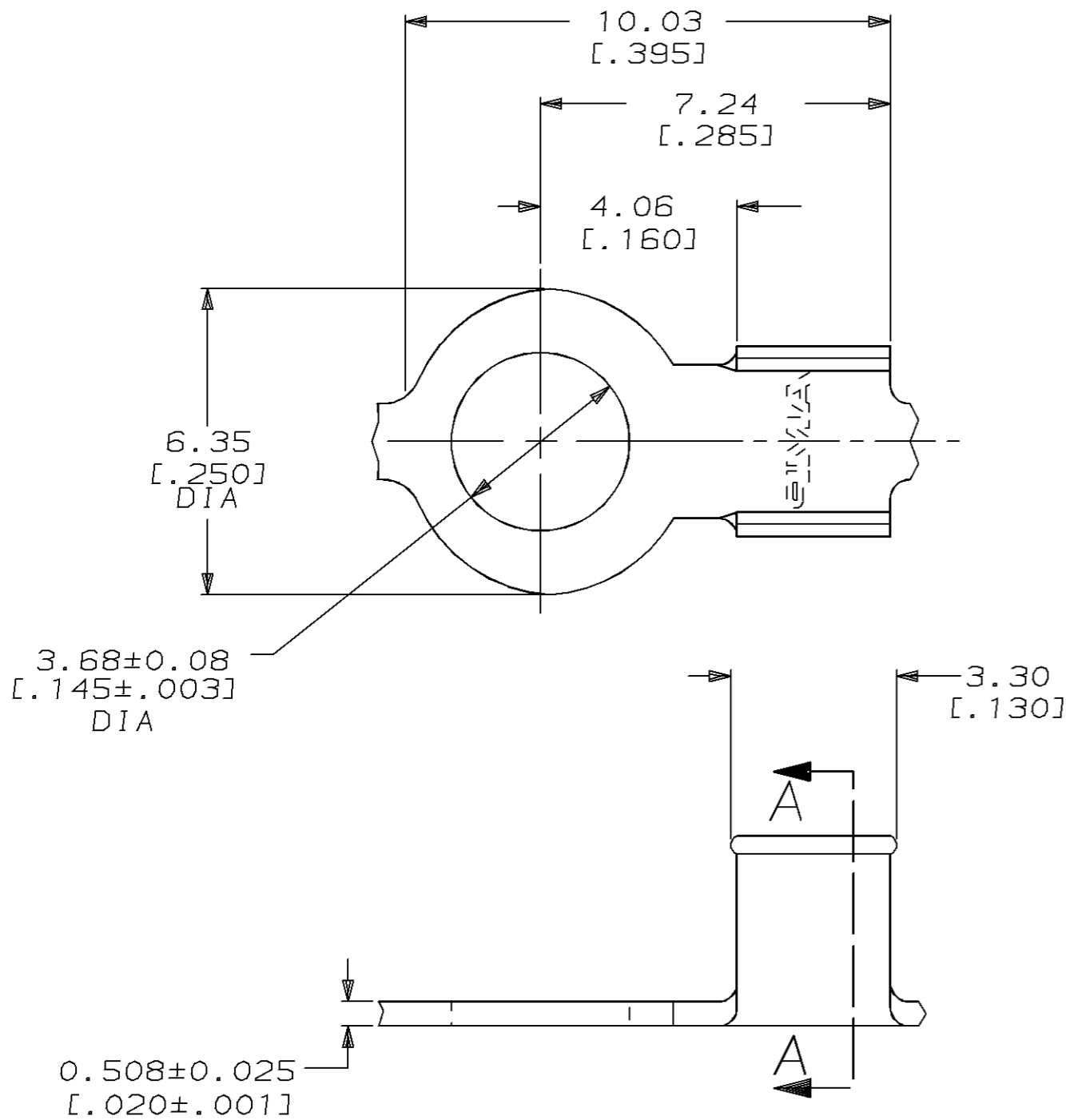

1 CONTINUOUS STRIP ON REEL.

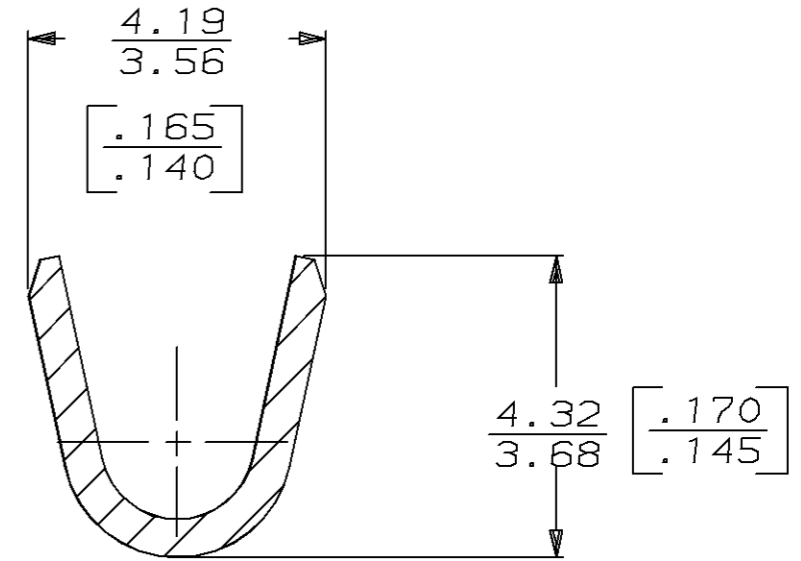

THIS DRAWING IS A CONTROLLED DOCUMENT FOR AMP INCORPORATED. IT IS SUBJECT TO CHANGE AND THE CONTROLLING ENGINEERING ORGANIZATION SHOULD BE CONTACTED FOR THE LATEST REVISION.

DO NOT SCALE PRINT. UNLESS SPECIFIED DIMENSIONS IN mm [INCHES] TOLERANCES ON:		DR 12/SEP/95 PHILLIP M FORTNEY	[20-14] AWG	40702
2 PLC DEC ± 0.25 [.010]		CHK 12/SEP/95 JEFF R RUTH	WIRE RANGE	PART NO
3 PLC DEC ± -		APPD 12/SEP/95 GARY YETTER	AMP AMP Incorporated Harrisburg, PA 17105-3608	
ANGLES ± -		APPD 12/SEP/95 MARK BARNABA	NAME	
MATERIAL	082 BRASS	PRODUCT SPEC -	RING	
FINISH	-	APPLICATION SPEC -	SIZE B	CAGE CODE 00779
		WEIGHT -	DRAWING NO C=40702	
			SCALE 8:1	SHEET 1 OF 1