

PART NO.	ENG. NO.
02-09-2166	4549-(P909)
02-09-2167	4549-(P909)L
02-09-3203	4549-(999)
-	-
-	-
-	-

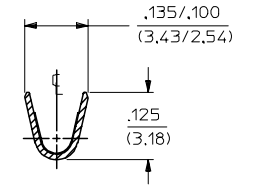
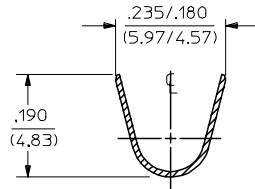
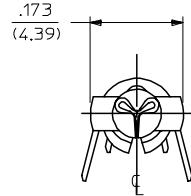

SECTION "A-A"

SECTION "B-B"

LEGEND
 4549-(****)*
 P=PREPLATE FINISH CODE
 BLANK=POSTPLATE FORM
 BLANK=CHAIN
 L=LOOSE

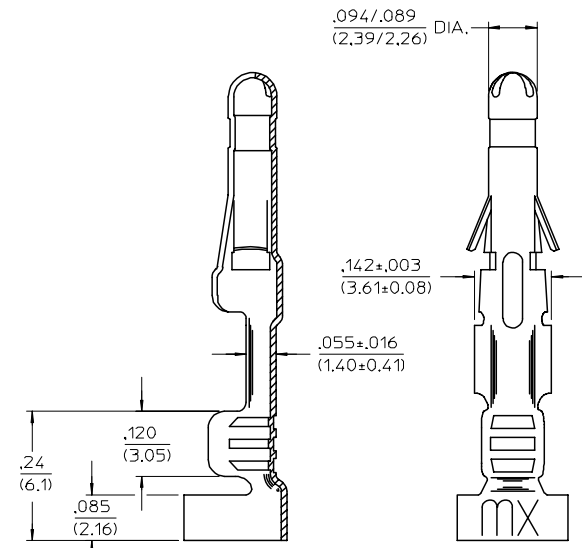
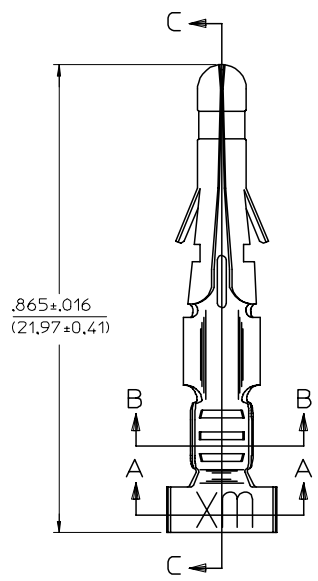

SECTION "C-C"

- NOTES:
- MATERIAL: PHOSPHOR BRONZE
 - FINISH CODES:
 999 UNPLATED
 909 HOT TIN DIP .000100/(0.00250) MIN.
 * THE PRIMARY SHIPPING CARTON WILL BE LABELED, "COMPLIANT TO RoHS 2002/95/EC AND ELV ANNEX II OF DIRECTIVE 2000/53/EC", AND CARTONS WITHOUT THIS LABEL MAY CONTAIN PRODUCT WITH TIN-LEAD.
 - PRODUCT SPECIFICATION: PS-02-09
 - PACKAGING INFORMATION: NOT AVAILABLE
 - TERMINAL FOR USE WITH .093/(2.36) SERIES HOUSINGS AND WILL ACCEPT 14 THRU 20 AWG WIRE.
 - INSERTION FORCE: 3.5 LBS. MAX. WHEN TERMINAL IS INSERTED INTO AN .093 SERIES HOUSING.
 - RETENTION: 20 LBS. MIN FROM HOUSING



LTR.	REVISIONS
C1	REMOVE STOP SIGN UCP2005-0278 RHOLTS 8/23/04
C	REVISED/REDRAWN UCP2005-0194 RHOLTS 7/30/04
B	ADD .(999) W/EDP * ECR U1 1880 12/28/92 RW
A	FINAL RELEASE ECR U1 0857 6/6/12/92 RW

REMOVE STOP SIGN EC NO: UCP2005-0278 DRAWN/RHOLTS 2004/08/27 CHKD/FSM/TH 2004/08/27 APPR/FSM/TH 2004/08/31	QUALITY SYMBOLS ▽=0 ▽=0	GENERAL TOLERANCES (UNLESS SPECIFIED)		DIMENSION STYLE IN/MM		SCALE 6:1	DESIGN UNITS INCH	THIRD ANGLE PROJECTION
		4 PLACES ± --- ± ---	3 PLACES ± --- ± .010	2 PLACES ± 0.25 ± .014	1 PLACE ± 0.35 ± ---	DRAWN BY GWC	DATE 1992/06/12	
C1	REV	ANGULAR ±1/2°		APPROVED BY GWF		DATE 1992/06/12	MATERIAL NO.	SHEET NO. 1 OF 1
		DRAFT WHERE APPLICABLE MUST REMAIN WITHIN DIMENSIONS		SEE CHART		DOCUMENT NO. SD-4549-*	MOLEX INCORPORATED	
THIS DRAWING CONTAINS INFORMATION THAT IS PROPRIETARY TO MOLEX INCORPORATED AND SHOULD NOT BE USED WITHOUT WRITTEN PERMISSION								