

THIS DRAWING IS UNPUBLISHED. RELEASED FOR PUBLICATION  
 © COPYRIGHT 19 BY AMP INCORPORATED. ALL INTERNATIONAL RIGHTS RESERVED.

LOC	DIST	P	F	ZONE	LTR	DESCRIPTION	DATE	APPD
G	14				H	REV / 0610-0026-99	12FEB99	MLE SU

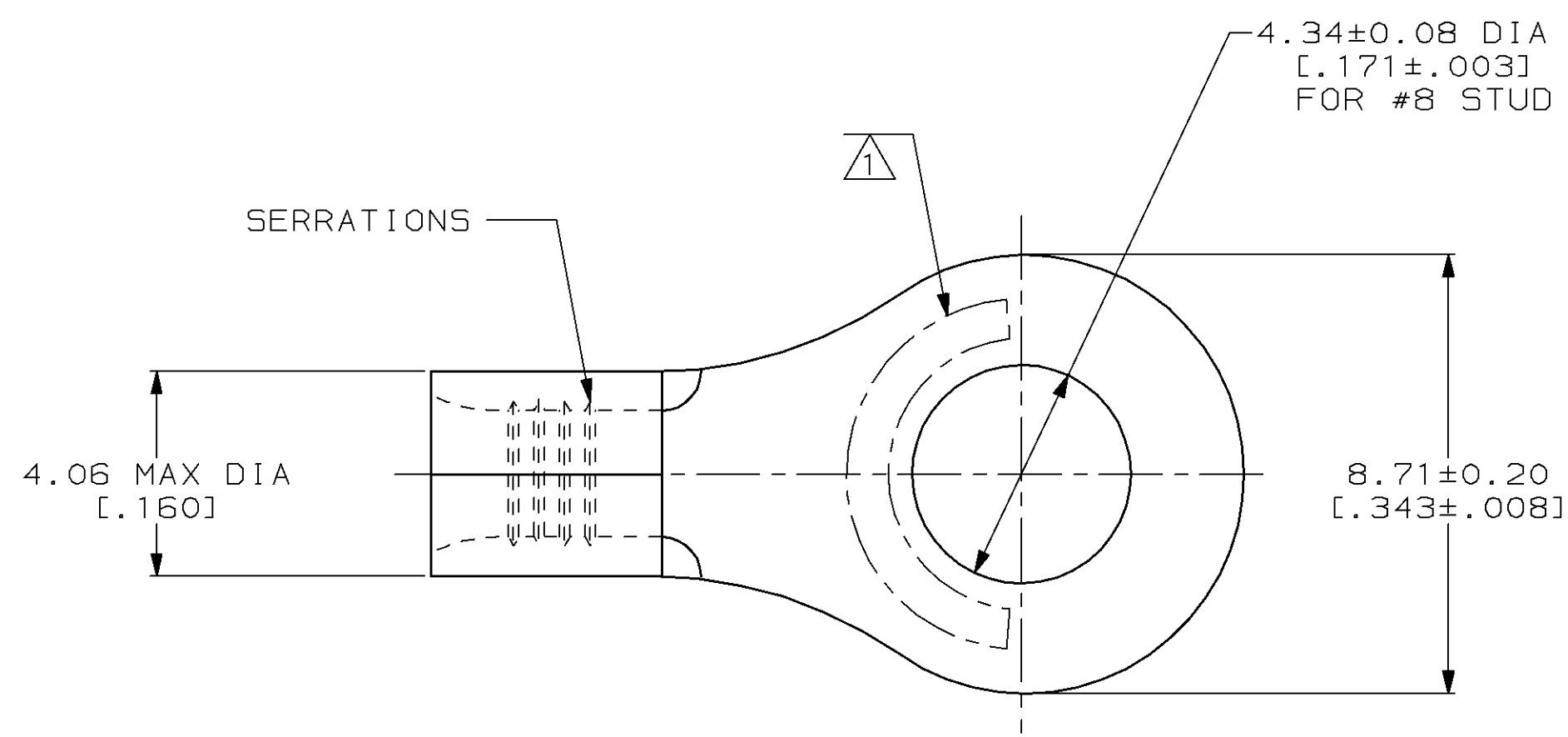

<b>AMP</b> WIRE RANGE	<b>UL</b> E13288 Listed
16-14 AWG STRANDED	16-14 AWG STRANDED
<b>LR7189</b> Certified	MILITARY P/N AND CLASS
NOT CERTIFIED	NOT APPLICABLE

1 STAMP AMP 16-14\* APPROX AS SHOWN

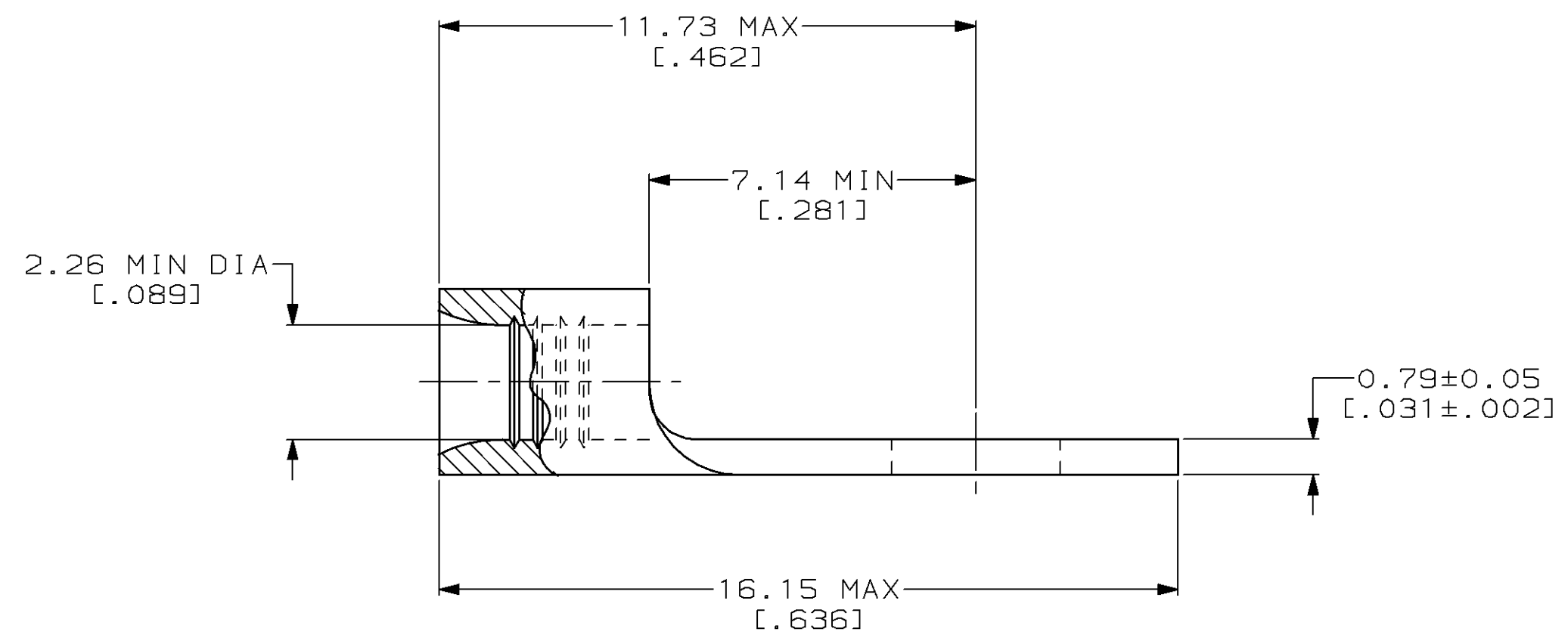

50	LOOSE PIECE, BOX	8-30696-2
5000	ON TAPE, REEL	2-30696-3
-	LOOSE PIECE	30696
QUANTITY	PACKAGE TYPE	AMP PART NUMBER

**AMP INCORPORATED**  
**CUSTOMER SERVICE SYSTEMS**

FOR ADDITIONAL PRODUCT INFORMATION OR COPIES OF DRAWINGS AND TECHNICAL DOCUMENTS

FOR APPLICATION TOOLING INFORMATION

FOR ORDER ENTRY

PRODUCT INFORMATION CENTER  
1-800-522-6752

TOOLING ASSISTANCE CENTER  
1-800-722-1111

1-800-526-5142

MAX RECOMMENDED OPERATING TEMPERATURE:  
170°C MAX

VOLTAGE RATING:  
NOT APPLICABLE

WIRE CROSS SECTIONAL AREA RANGE:  
1.04-2.62mm<sup>2</sup> [2,050-5,180] CIR MILS STRANDED

THIS DRAWING IS A CONTROLLED DOCUMENT FOR AMP INCORPORATED. IT IS SUBJECT TO CHANGE AND THE CONTROLLING ENGINEERING ORGANIZATION SHOULD BE CONTACTED FOR THE LATEST REVISION.

DO NOT SCALE PRINT. UNLESS SPECIFIED DIMENSIONS IN mm [INCHES]

TOLERANCES ON:  
 2 PLC DEC ± -  
 3 PLC DEC ± -  
 ANGLES ± -

MATERIAL  
 COPPER PER ASTM B-152 ANNEALED

FINISH  
 TIN PLATE 0.00254 [.000100] MIN THK PER ASTM B-545

DR 2-4-93  
TA BRINKMAN

CHK 2-4-93  
DA PATTERSON

APPD 2-4-93  
DE MILLER

APPD 2-4-93  
JL MECKLEY

PRODUCT SPEC -

APPLICATION SPEC -

WEIGHT -

**AMP** AMP Incorporated  
 Harrisburg, PA 17105-3608

NAME  
**TERMINAL, RING TONGUE, BUDGET**

SIZE CAGE CODE DRAWING NO  
 C 00779 C=30696

SCALE 8:1 SHEET 1 OF 1