

REFERENCE:

PERFORMANCE REQUIREMENTS AT DRY AS MOLDED:

1. FIR TREE PUSH IN FORCE: REF. 10 LBS MAX IN A 6.5mm HOLE AND A PLATE THICKNESS OF 1.8mm
2. FIR TREE PULL OUT FORCE: REF. 30 LBS MIN IN A 6.5mm HOLE AND A PLATE THICKNESS OF 1.8mm
3. SHEET METAL THICKNESS RANGE: 0.70mm - 18.0mm
4. CIRCULAR HOLE SIZE DIAMETER: 6.5 +/- 0.30mm

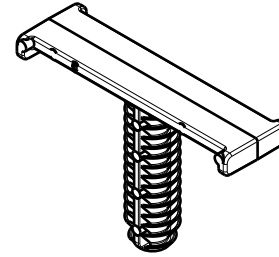

Isometric view  
Scale: 1:1

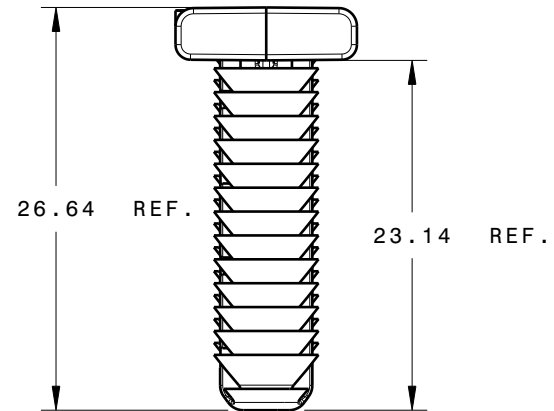
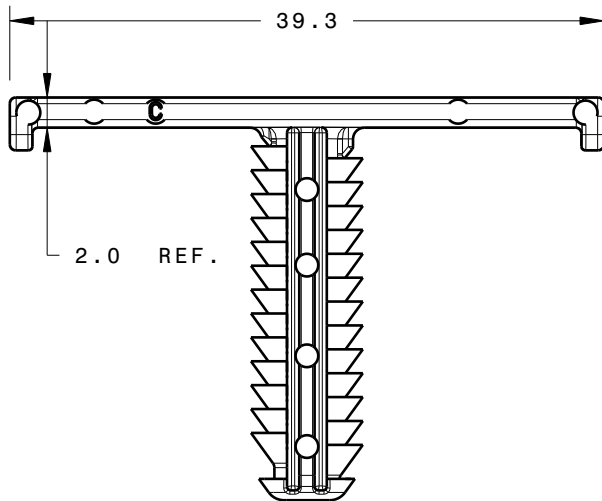
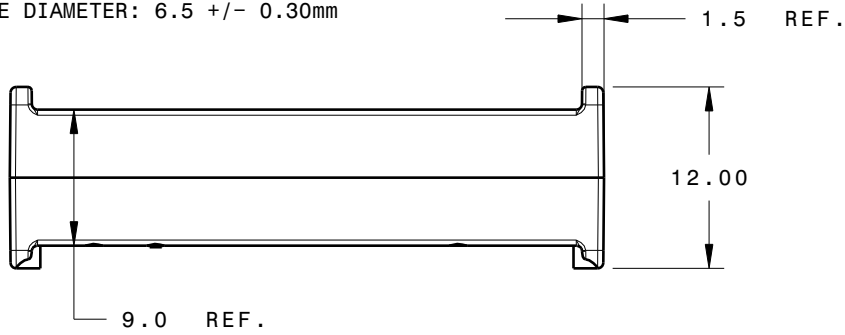

INVENTORS

**HellermannTyton**<sup>®</sup>

ALL PROPRIETARY RIGHTS IN THE SUBJECT MATTER SHOWN ON THIS DRAWING ARE EXCLUSIVE PROPERTY OF HELLERMANN TYTON

name	date	city, state
S. ADAMS	3/20/2007	MENOMONEE FALLS, WI.

REVISIONS

REV	level	DATE	BY	ECN #	part level
A	05	10/30/08	SJA	011145	C

DIMENSIONS

TOLERANCES	units
.XXXX = ± 0.25	millimeters
.XXX = ± 0.50	
.XX = ± 1.00	
.X = ± 2.00	
∠ = ± 0.50	
unless otherwise specified	

PART

number	TC6FT6LG	phase	PRODUCTION
name	TAPE CLIP		
material	NYLON 6/6, IMPACT MODIFIED, HEAT STABILIZED COLOR: NATURAL		

DRAWING

FORMAT	AH	CAD	CATIA V5	SCALE
VERSION	J			2:1
A- SIZE (landscape)_N01	previous drawing number			
drawn	S. ADAMS	checked	J. PASSILLA	approved
	12/07/07		12/07/07	
type	CUSTOMER		sheet 1 of 1	
number	MT07-054-001CST			