

CM2022X330R-10

PHYSICAL DIMENSIONS:

A	5.70 [.224]	±	0.20 [.008]
B	2.80 [.110]	±	0.30 [.012]
C	4.60 [.181]	±	0.30 [.012]
C1	6.70 [.264]	±	0.20 [.008]
E	2.00 [.079]	±	0.20 [.008]

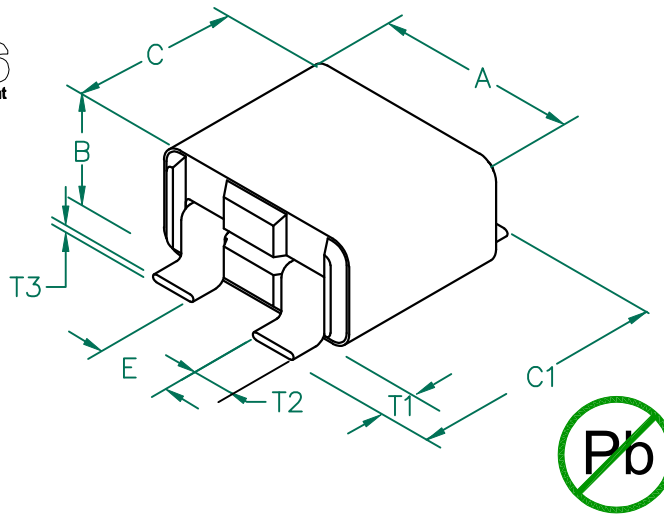

WIRE DIMENSIONS:

T1	0.90 [.035]	+	0.20 [.008]	-	0.10 [.004]
T2	1.27 [.050]		REF.		
T3	0.20 [.008]		REF.		

Z vs. FREQUENCY (C,N,O)

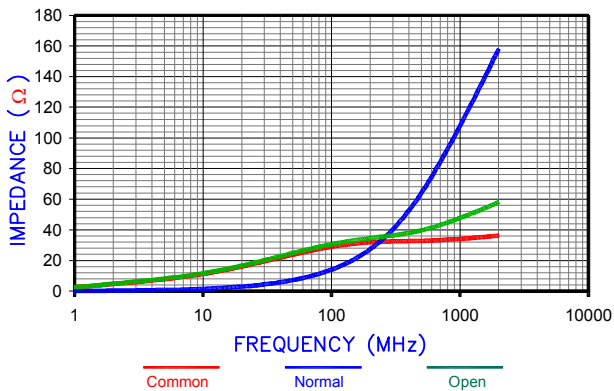

Z, R, XL vs. FREQUENCY

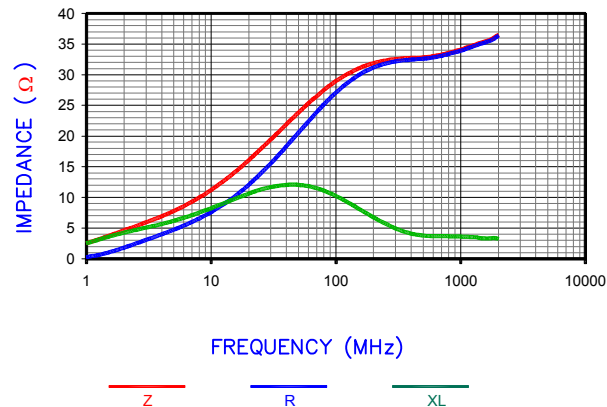

LAND PATTERNS FOR REFLOW SOLDERING

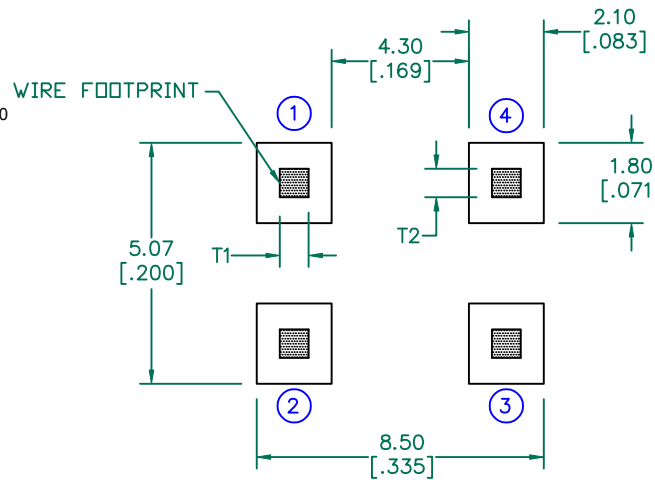

ELECTRICAL CHARACTERISTICS:

	Z in (Ω)			DCR (Ω)	Rated Current (Continuous)
	⊕ 25 MHZ	⊕ 100 MHZ	⊕ 300 MHZ		
Nominal (Ref.)	20	33	36		
Minimum	-	25	-		
Maximum	-	-	-	.00075	10,000 mA

NOTES: UNLESS OTHERWISE SPECIFIED

1. TAPED AND REELED per CURRENT EIA SPECIFICATIONS, 13" REELS, PENDING PCS PER REEL
2. COMPONENTS SHOULD BE ADEQUATELY PREHEATED BEFORE SOLDERING.
3. REF.CARRIER TAPE SPECIFICATION PENDING.
4. THIS PART HAS NO PIN POLARITY.
5. TERMINATION FINISH IS 100% TIN.

UNCONTROLLED DOCUMENT

RECOMMENDED SOLDERING CONDITIONS

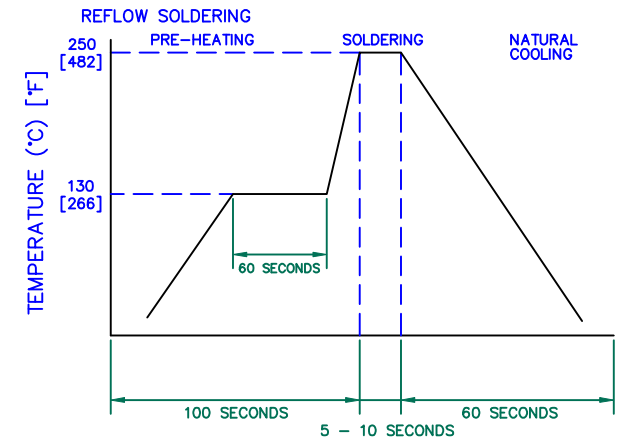

DIMENSIONS ARE IN mm [INCHES].

THIS DOCUMENT CONTAINS INFORMATION WHICH IS PROPRIETARY AND CONFIDENTIAL TO STEWARD. NO PRODUCTION OR PUBLICATION OF THIS DOCUMENT IN WHOLE OR IN PART SHALL BE MADE WITHOUT WRITTEN AUTHORIZATION FROM STEWARD.

Steward

PROJECT/PART NUMBER: **CM2022X330R-10** REV: **A** PART TYPE: **ASSEMBLY** DRAWN BY: **JRK**

DATE: **07/27/05** SCALE: **NTS** SHEET: **2 of 3**